

ALPHA-Mix V2 160/220 Mixing Machine

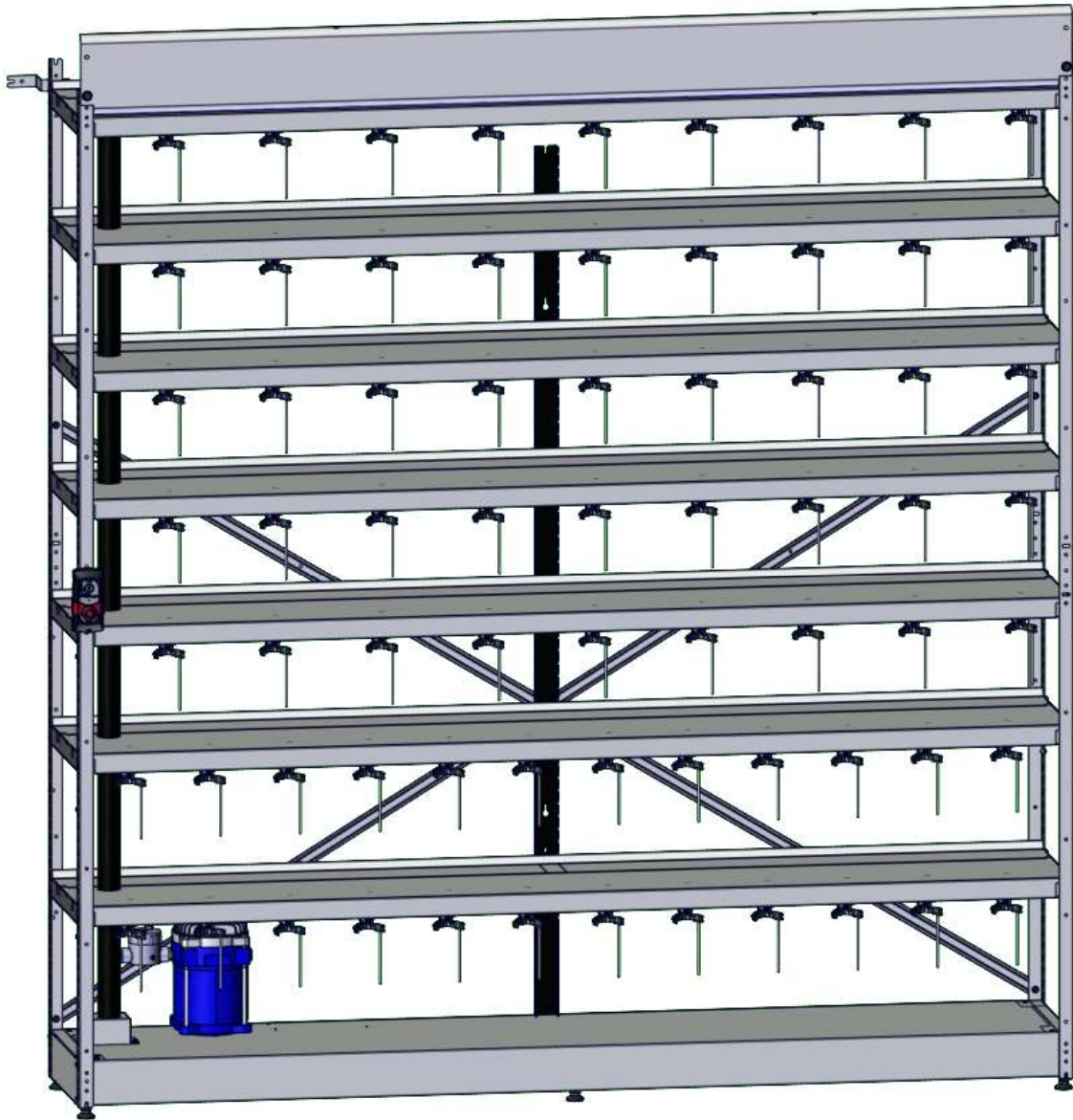

 VIDEO



E23150 B



243584

CONTENTS

- II. SAFETY INSTRUCTIONS (PAGE 3)**
- III. GENERAL RECOMMENDATIONS (PAGE 4)**
- IV. COMPONENTS (PAGES 5)**
- V. INSTALLATION (PAGES 6-23)**
- VI. CONFIGURATIONS GUIDE (PAGE 24)**
- VII. ELECTRICAL INSTALLATION (PAGE 25)**
- VIII. OPERATION (PAGE 26)**
- IX. PROGRAMMING THE TIMER (PAGE 27)**
- X. TROUBLESHOOTING (PAGE 28)**
- XI. SPARE PARTS (PAGE 29)**
- XII. WARRANTY MOTOR POLICY (PAGE 30)**





SAFETY PRECAUTIONS :

ALWAYS PROTECT HANDS WITH INDUSTRIAL SAFETY GLOVES WEAR SUITABLE EYEWEAR PROTECTION
DISCONNECT THE MACHINE FROM THE ELECTRICAL SOURCE BEFORE MAINTENANCE
DO NOT SMOKE OR IGNITE AN OPEN FLAME NEAR EXPLOSIVE PAINTS AND CHEMICALS

SAFETY INSTRUCTIONS

BEFORE INSTALLATION:

Always wear safety gloves and glasses.

Never smoke or operate the machine near an open flame.

SAFETY INSTRUCTIONS

IMPORTANT:

Mixing machines must be hardwired in hazardous locations (Class 1, Division 1, Group D) in accordance with Federal, State/Province, and local regulations by a qualified licensed electrician.

1. Install the mixing machine on level surface and away from dampness or nearby heat sources.
2. Never attempt to open, repair, or modify an explosion-proof motor.
3. Don't operate the mixing machine without the protective drive shaft covers in-place.
4. For stability purposes it is recommended as a best practice to place gallon cans on the lower shelves.
5. Never operate the mixing machine without the cross-braces installed/secured and do not lean against the unit.
6. Make certain that the mixing lids are properly secured onto cans before placing them onto the machine.
7. Don't overreach or stand on a mixing shelf when trying to reach cans on the top-most shelves.
8. Never use water to wash down or clean the machine.
9. [Secure the mixing machine to the wall with the brackets provided.](#)
10. When attempting repairs (i.e. replacing worn belts etc.) always disconnect the machine from the power source.

FILLON TECHNOLOGIES assumes no responsibility or liability for any accidents or actions taken beyond the scope of these safety instructions.

CAUTION: Sheet metal edges can be sharp. Never attempt to install a machine or replace mixing shelf without wearing safety gloves.





SAFETY PRECAUTIONS :

ALWAYS PROTECT HANDS WITH INDUSTRIAL SAFETY GLOVES WEAR
SUITABLE EYEWEAR PROTECTION
DISCONNECT THE MACHINE FROM THE ELECTRICAL SOURCE BEFORE
MAINTENANCE
DO NOT SMOKE OR IGNITE AN OPEN FLAME NEAR EXPLOSIVE PAINTS AND
CHEMICALS

GENERAL RECOMMENDATIONS

Install the mixing machine in a ventilated mixing room at an ambient temperature between +5°C (41°F) to +40°C (104°F) in accordance with your local safety guidelines for Explosion-Proof installations.

Allow about a foot behind the mixing machine to facilitate the electrical connections. Using the wall-mount brackets (see installation) then measure the appropriate distance accordingly.





SAFETY PRECAUTIONS :

ALWAYS PROTECT HANDS WITH INDUSTRIAL SAFETY GLOVES WEAR SUITABLE EYEWEAR PROTECTION
DISCONNECT THE MACHINE FROM THE ELECTRICAL SOURCE BEFORE MAINTENANCE
DO NOT SMOKE OR IGNITE AN OPEN FLAME NEAR EXPLOSIVE PAINTS AND CHEMICALS

COMPONENTS

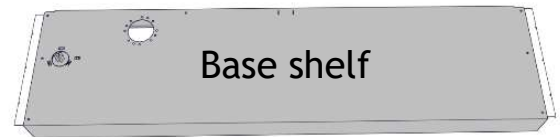
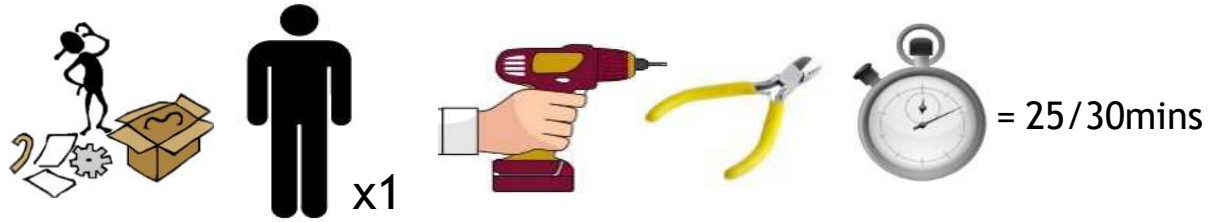

Uprights with cross-braces

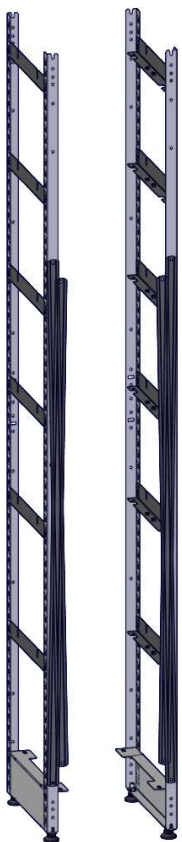

rear rail

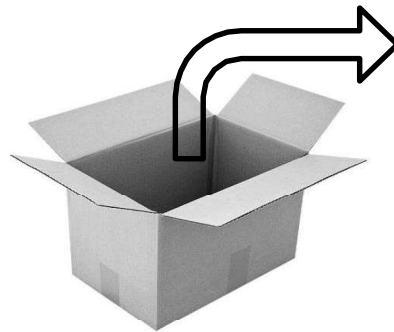

Rear bracket

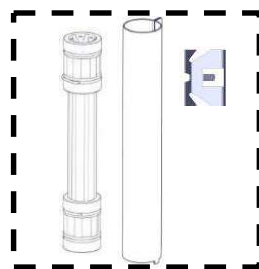
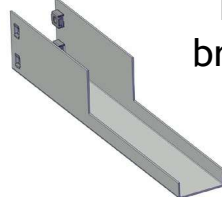

Drive shafts

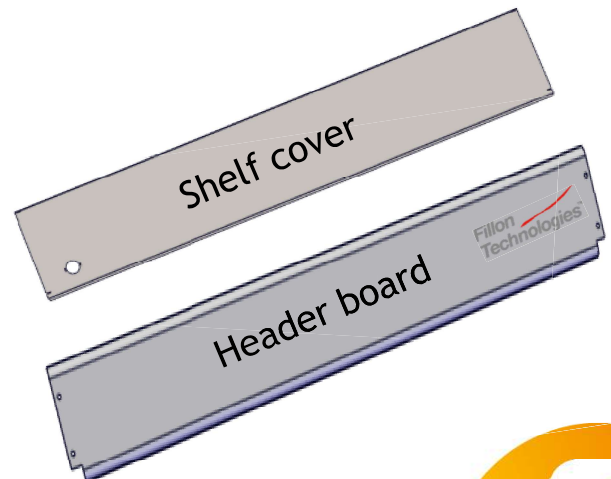
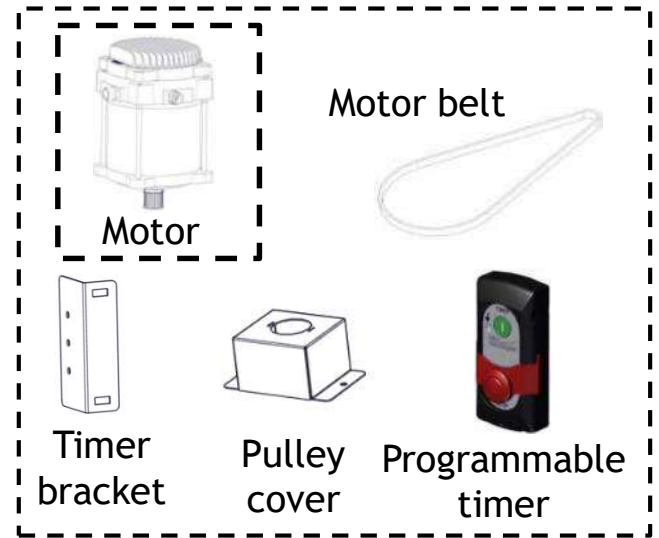



SAFETY PRECAUTIONS :

ALWAYS PROTECT HANDS WITH INDUSTRIAL SAFETY GLOVES WEAR SUITABLE EYEWEAR PROTECTION
DISCONNECT THE MACHINE FROM THE ELECTRICAL SOURCE BEFORE MAINTENANCE
DO NOT SMOKE OR IGNITE AN OPEN FLAME NEAR EXPLOSIVE PAINTS AND CHEMICALS

INSTALLATION

Motor & Structure

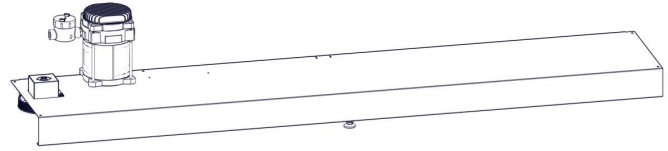

4x  M6x12

1

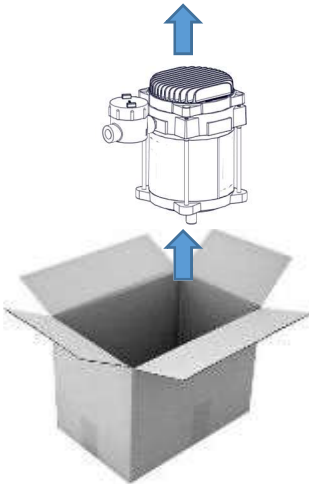

Motor carton

Step 1: Install the Explosion-Proof Motor onto the base structure by placing the motor upside down on one side along with the cardboard carton of the motor on the opposite end for support. Then lay the structure across while lining up the bolt holes before securing it with 4 x 12 mm bolts provided and tighten.

2



Empty Motor carton

Step 2: Install the motor belt onto the motor and large pulley then check to ensure that it rotates freely.





SAFETY PRECAUTIONS :

ALWAYS PROTECT HANDS WITH INDUSTRIAL SAFETY GLOVES WEAR SUITABLE EYEWEAR PROTECTION
DISCONNECT THE MACHINE FROM THE ELECTRICAL SOURCE BEFORE MAINTENANCE
DO NOT SMOKE OR IGNITE AN OPEN FLAME NEAR EXPLOSIVE PAINTS AND CHEMICALS

INSTALLATION

Motor & Structure

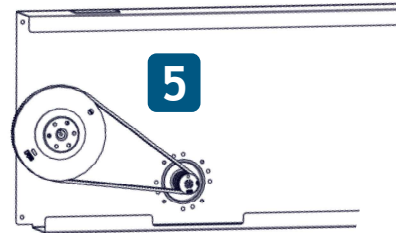
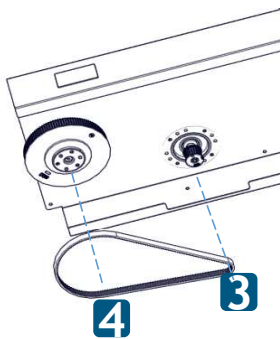
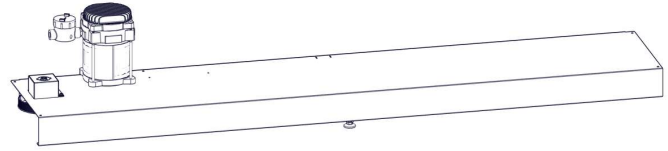

Step 3: Turn the base structure upright (from the motor side) while taking care to adequately protect the motor during this process. Note: this step is easier with two persons. Alternatively, if you're assembling the machine alone then turn the structure on its side and connect the motor from behind with the plate facing up.





SAFETY PRECAUTIONS :

ALWAYS PROTECT HANDS WITH INDUSTRIAL SAFETY GLOVES WEAR SUITABLE EYEWEAR PROTECTION
DISCONNECT THE MACHINE FROM THE ELECTRICAL SOURCE BEFORE MAINTENANCE
DO NOT SMOKE OR IGNITE AN OPEN FLAME NEAR EXPLOSIVE PAINTS AND CHEMICALS

INSTALLATION

Motor & Structure

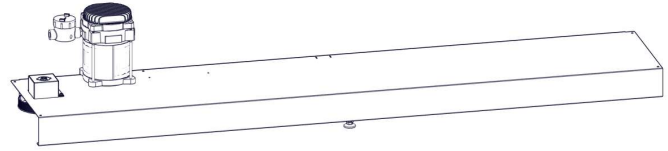

3x  M6x12

A49

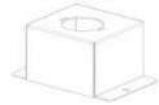

Step 4: Install the pulley cover protector of the main driving block using the three holes provided with 3 x 12mm bolts

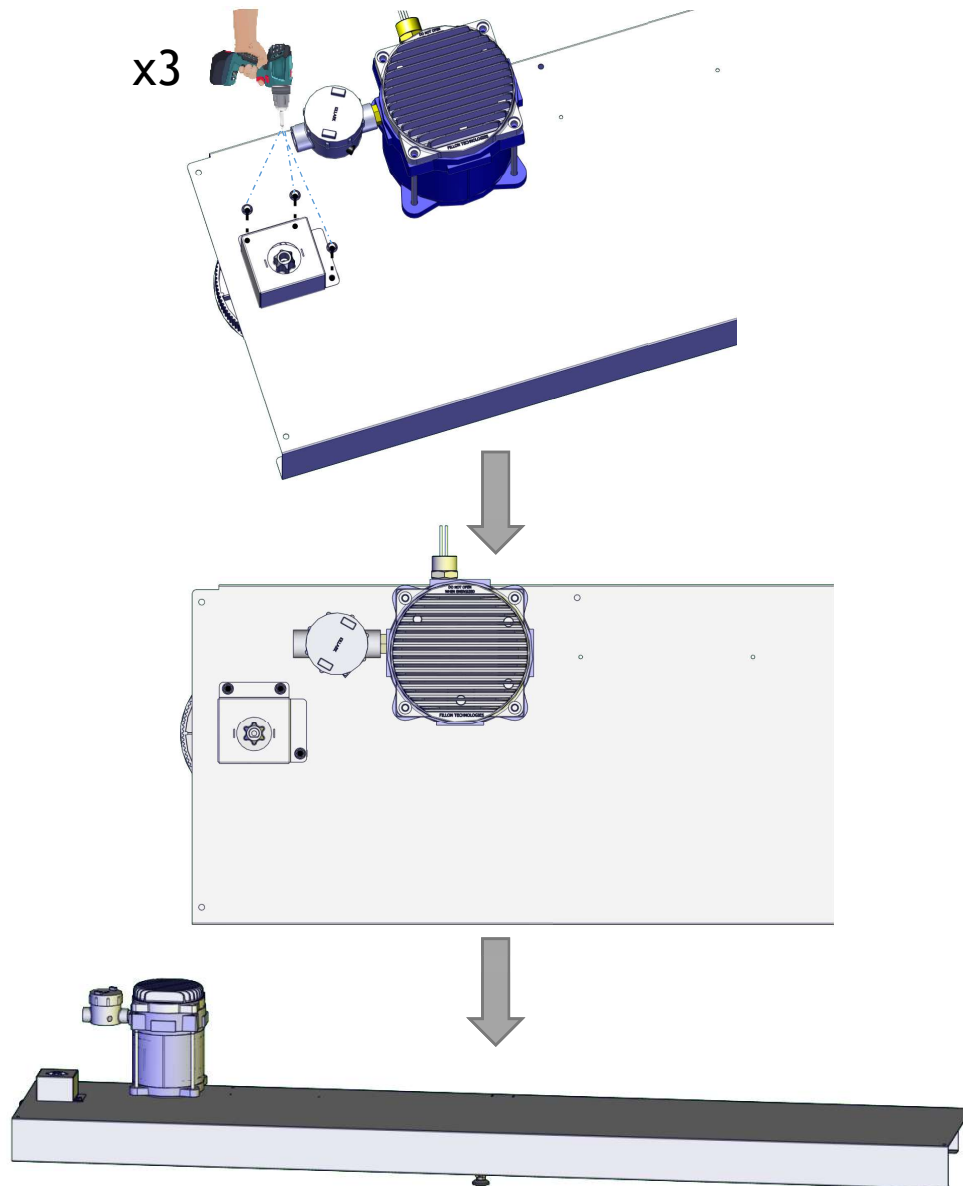



SAFETY PRECAUTIONS :

ALWAYS PROTECT HANDS WITH INDUSTRIAL SAFETY GLOVES WEAR SUITABLE EYEWEAR PROTECTION
DISCONNECT THE MACHINE FROM THE ELECTRICAL SOURCE BEFORE MAINTENANCE
DO NOT SMOKE OR IGNITE AN OPEN FLAME NEAR EXPLOSIVE PAINTS AND CHEMICALS

INSTALLATION

Attaching the Uprights



Step 5: Begin by installing the LH upright onto the motor side of the base structure by lining up the bolt holes and securing it with 2x provided 12 mm bolts.
Step 6: Install the RH upright onto the opposite side of the base structure then tighten securely with pre-assembled 12 mm bolts.

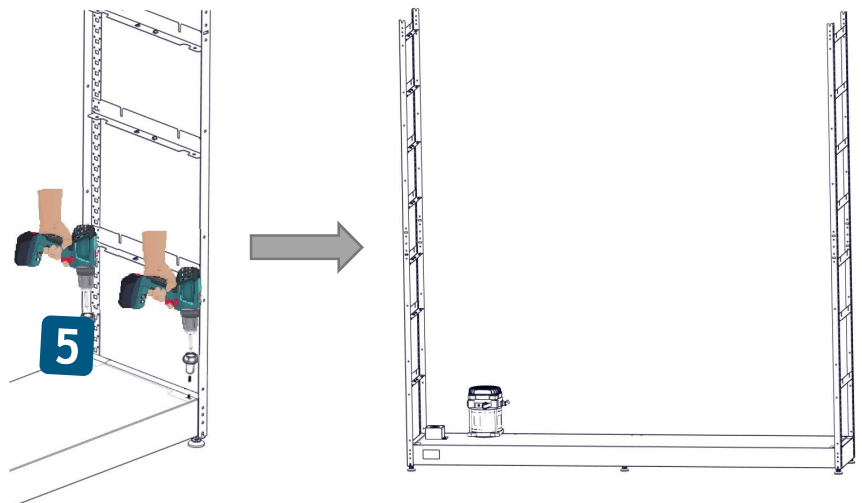
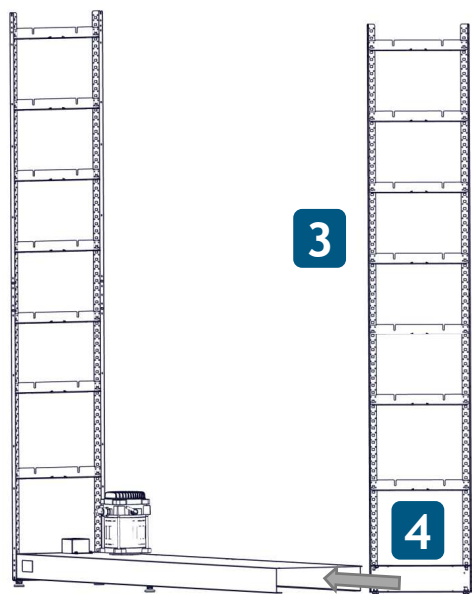
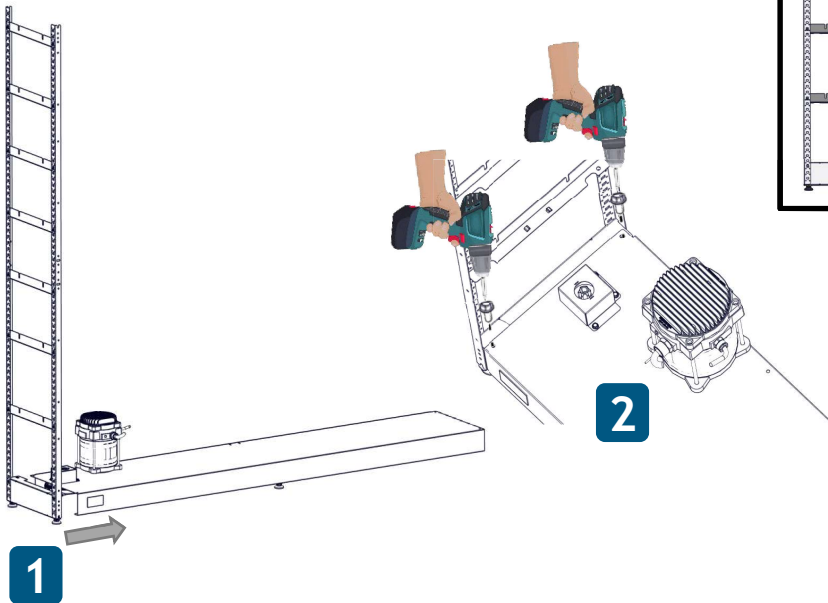
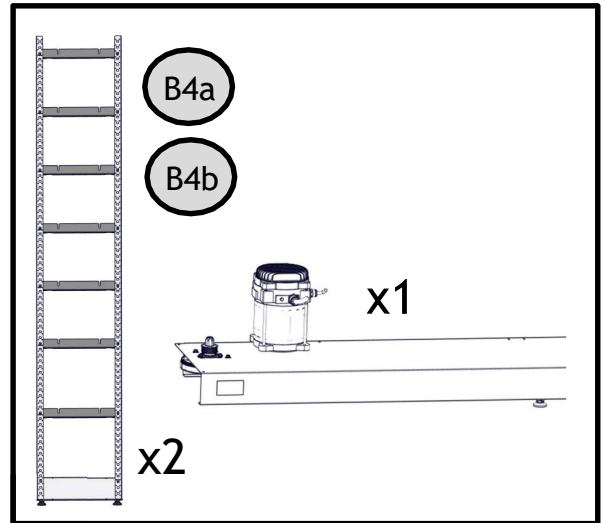



SAFETY PRECAUTIONS :

ALWAYS PROTECT HANDS WITH INDUSTRIAL SAFETY GLOVES WEAR SUITABLE EYEWEAR PROTECTION
DISCONNECT THE MACHINE FROM THE ELECTRICAL SOURCE BEFORE MAINTENANCE
DO NOT SMOKE OR IGNITE AN OPEN FLAME NEAR EXPLOSIVE PAINTS AND CHEMICALS

INSTALLATION

Cross-braces for Alpha-Mix 220

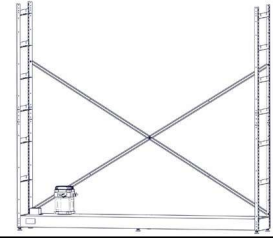

1x  M6x20

1x 

Step 7: The cross-braces have been pre-installed on the structure to ease the assembly. To access the braces cut the protective bands on each side using pliers or utility knife.

Step 8: Connect both ends of the cross-braces by joining them together in the middle and then securing them with the long bolt (3/4") provided. Note: this action can be managed while facing the front of the machine. Tighten the 4 upright screws.

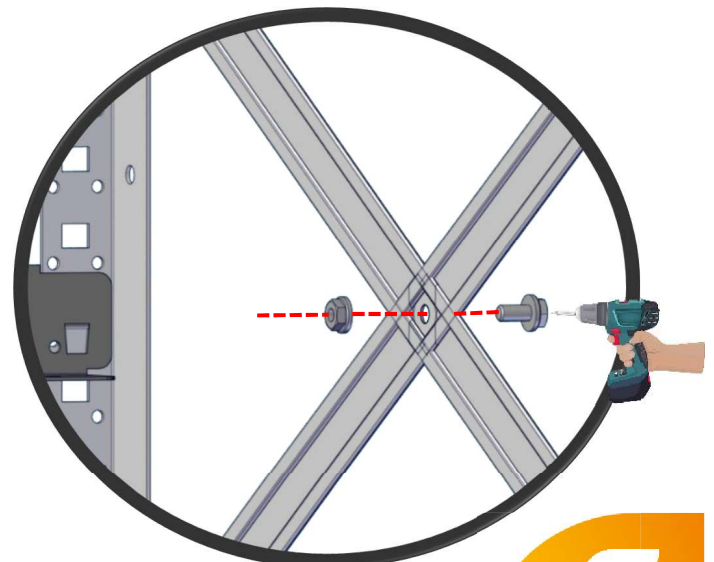
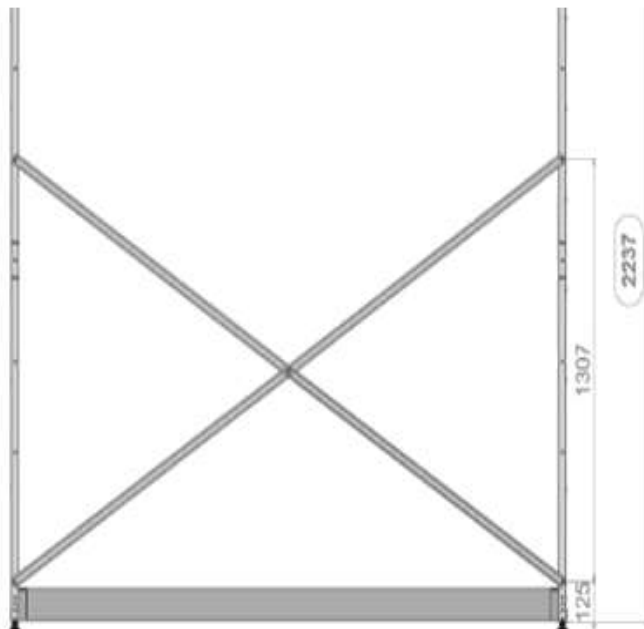
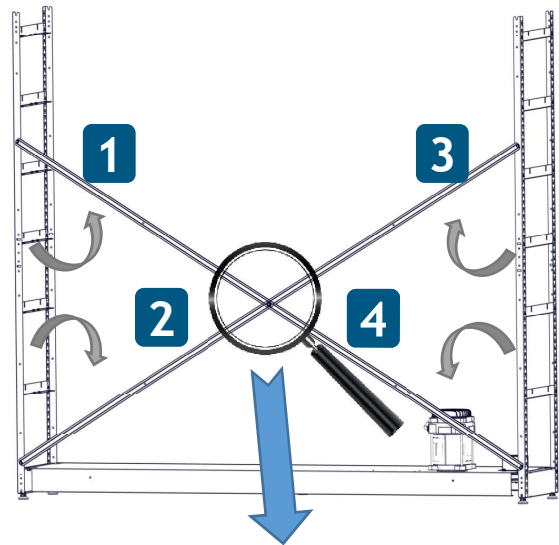
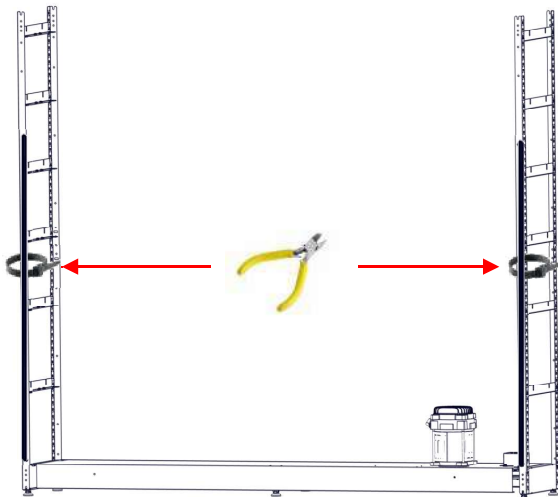



SAFETY PRECAUTIONS :

ALWAYS PROTECT HANDS WITH INDUSTRIAL SAFETY GLOVES WEAR SUITABLE EYEWEAR PROTECTION
DISCONNECT THE MACHINE FROM THE ELECTRICAL SOURCE BEFORE MAINTENANCE
DO NOT SMOKE OR IGNITE AN OPEN FLAME NEAR EXPLOSIVE PAINTS AND CHEMICALS

INSTALLATION

Cross-braces for Alpha-Mix 160

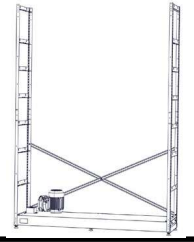

2x M6x12 1x M6x20 3X

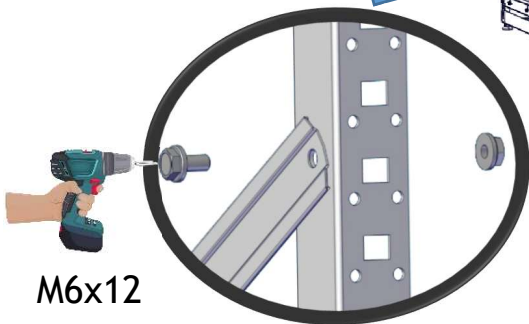
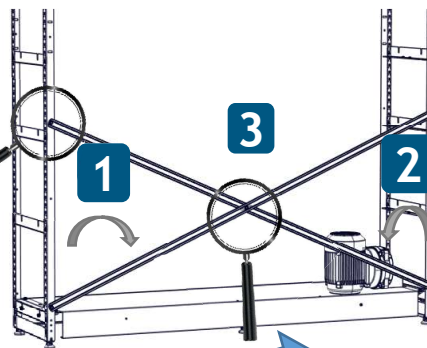
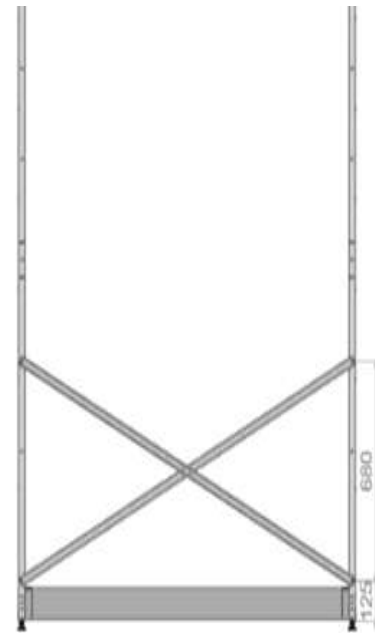
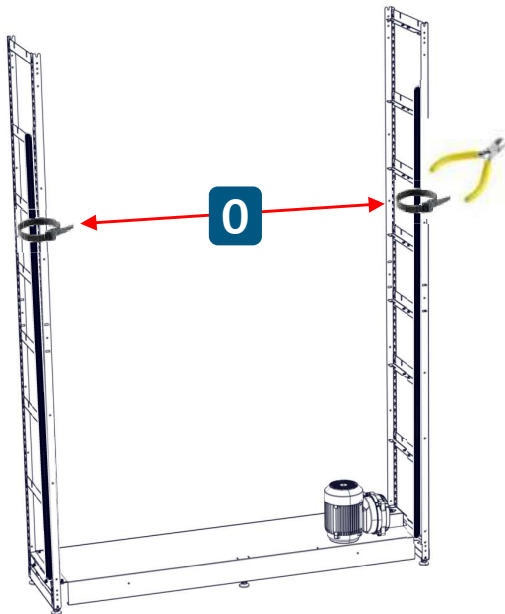

M6x12

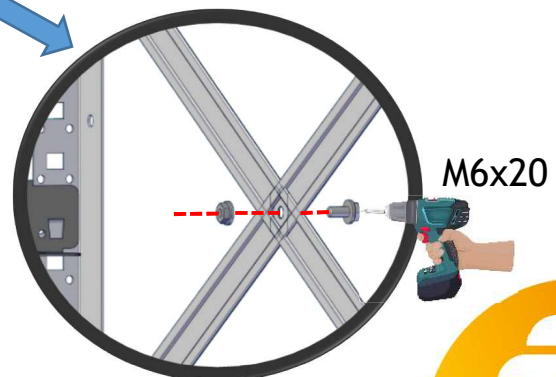

M6x20





SAFETY PRECAUTIONS :

ALWAYS PROTECT HANDS WITH INDUSTRIAL SAFETY GLOVES WEAR SUITABLE EYEWEAR PROTECTION
DISCONNECT THE MACHINE FROM THE ELECTRICAL SOURCE BEFORE MAINTENANCE
DO NOT SMOKE OR IGNITE AN OPEN FLAME NEAR EXPLOSIVE PAINTS AND CHEMICALS

INSTALLATION



1

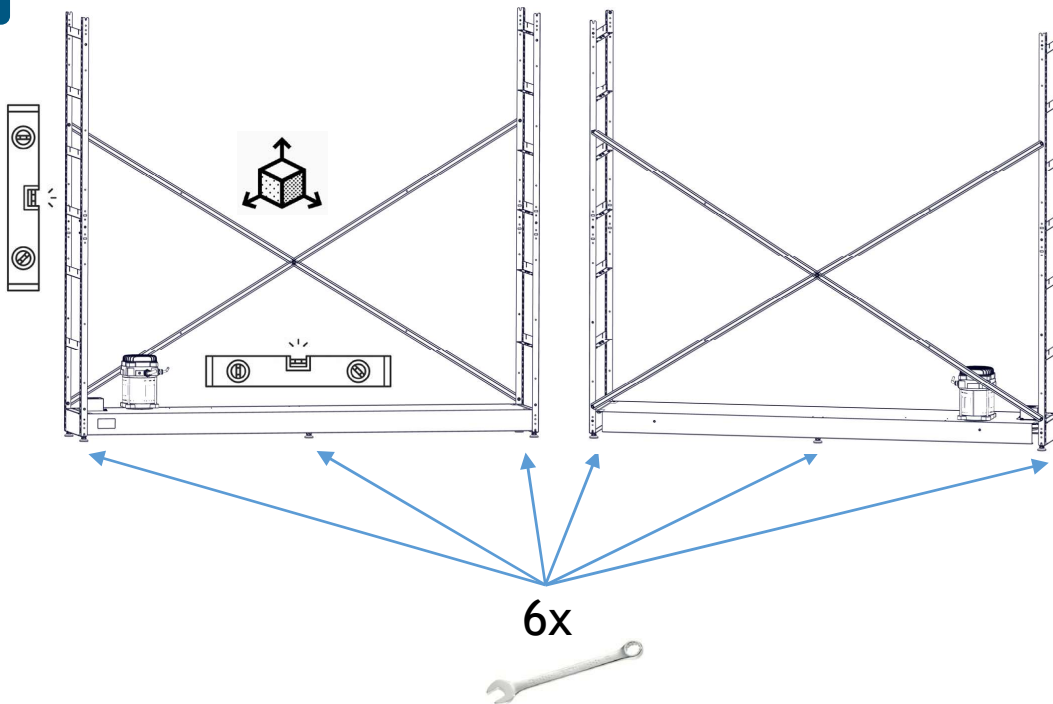

Step 9: Adjust the 6x leveling feet up to a maximum height of 35mm to accommodate uneven floors.

2

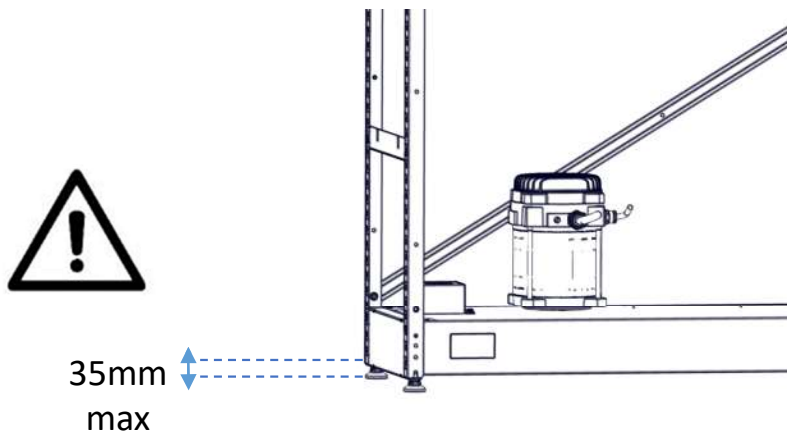



SAFETY PRECAUTIONS :

ALWAYS PROTECT HANDS WITH INDUSTRIAL SAFETY GLOVES WEAR SUITABLE EYEWEAR PROTECTION
DISCONNECT THE MACHINE FROM THE ELECTRICAL SOURCE BEFORE MAINTENANCE
DO NOT SMOKE OR IGNITE AN OPEN FLAME NEAR EXPLOSIVE PAINTS AND CHEMICALS

INSTALLATION

Installing the base shelf drive shaft and mixing shelf

ONLY →

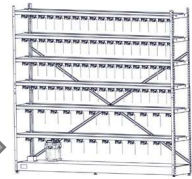

Included with the base structure is a special drive shaft for installations that require gallon-sized cans on the bottom shelf. The part # for the special drive shaft is AYYY1443.

IMPORTANT: Do not attempt to install a standard quart or gallon sized drive shaft on the lowermost shelf or damage to the machine will occur.

Step 10: To install the base drive shaft, insert the drive sleeve into the main drive block. Then insert the drive shaft with the spring into the guide on the mechanical shelf.

Step 11: Remove shelf cover. Install the mechanical shelf by sliding the drive shaft into the sleeve and aligning them with the front and rear tabs on the shelf supports.

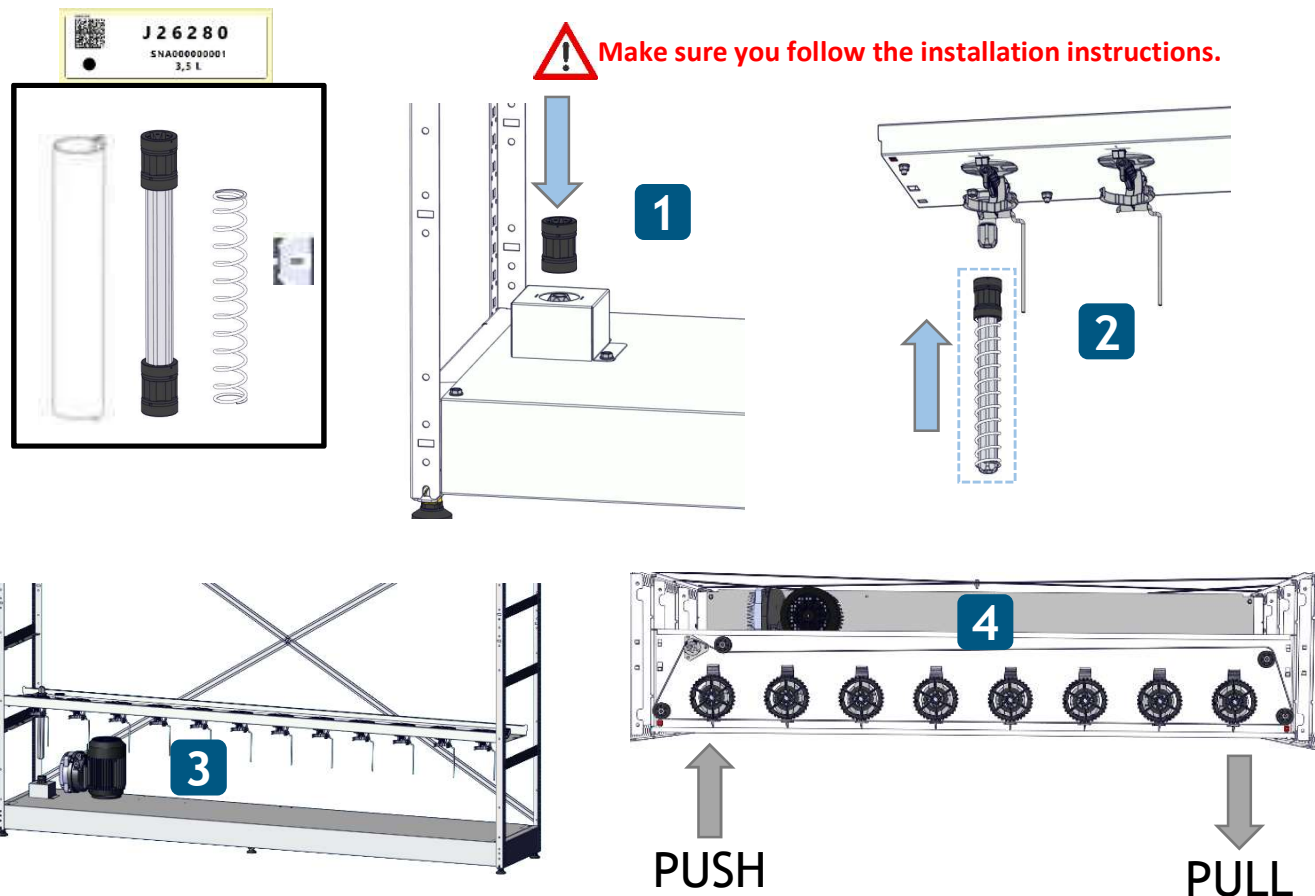

Note: When installing mixing shelves, it is important to PUSH the shelf backward and then PULL forward to lock it securely into place.





SAFETY PRECAUTIONS :

ALWAYS PROTECT HANDS WITH INDUSTRIAL SAFETY GLOVES WEAR SUITABLE EYEWEAR PROTECTION
DISCONNECT THE MACHINE FROM THE ELECTRICAL SOURCE BEFORE MAINTENANCE
DO NOT SMOKE OR IGNITE AN OPEN FLAME NEAR EXPLOSIVE PAINTS AND CHEMICALS

INSTALLATION

Installing the base shelf drive shaft and mixing shelf

ONLY →

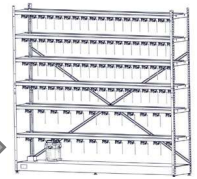

Installing quart or liter cans on the base shelf

If you prefer to have to quart or liter size cans on the base shelf, then contact Fillon Technologies and order part # AYYY1447.

Warning: Do not attempt to use any other drive shaft reference than recommended.

2x  M6x12 per shelf

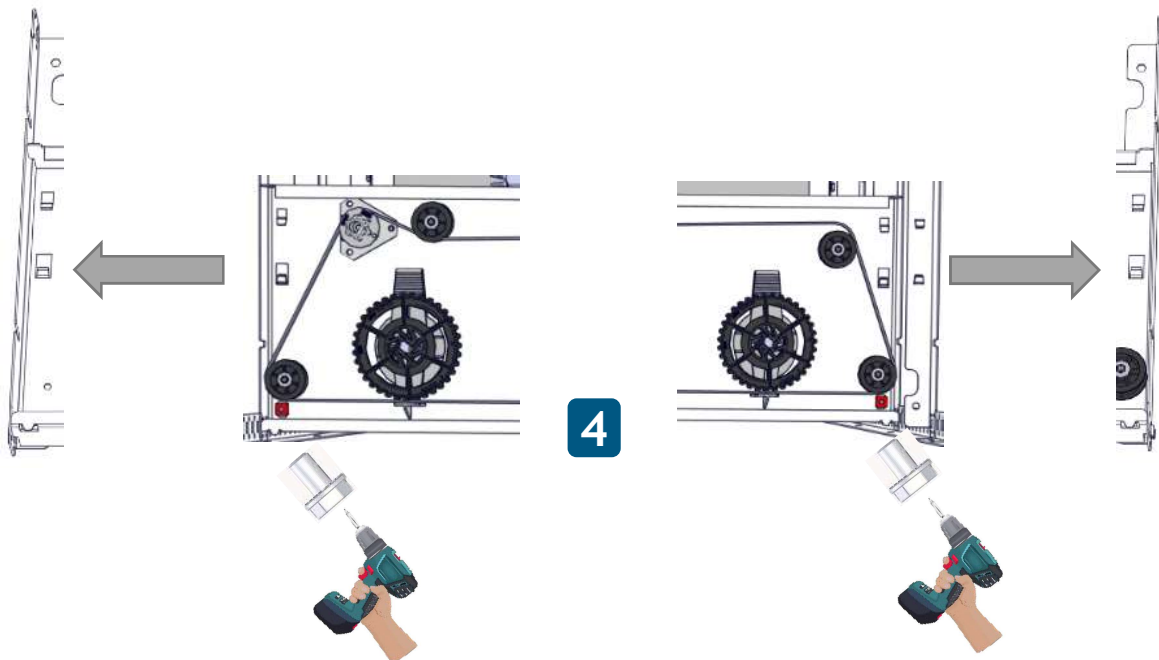

Step 12: Secure the mixing shelf into place on both ends with bolts.





SAFETY PRECAUTIONS :

ALWAYS PROTECT HANDS WITH INDUSTRIAL SAFETY GLOVES WEAR SUITABLE EYEWEAR PROTECTION
DISCONNECT THE MACHINE FROM THE ELECTRICAL SOURCE BEFORE MAINTENANCE
DO NOT SMOKE OR IGNITE AN OPEN FLAME NEAR EXPLOSIVE PAINTS AND CHEMICALS

INSTALLATION

Installing the galvanized shelf covers on top of the mechanical shelves **ONLY**

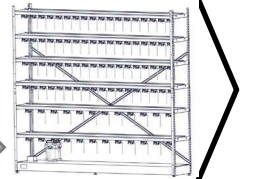

Step 13: Install the shelf cover on the top of the mechanical shelf.

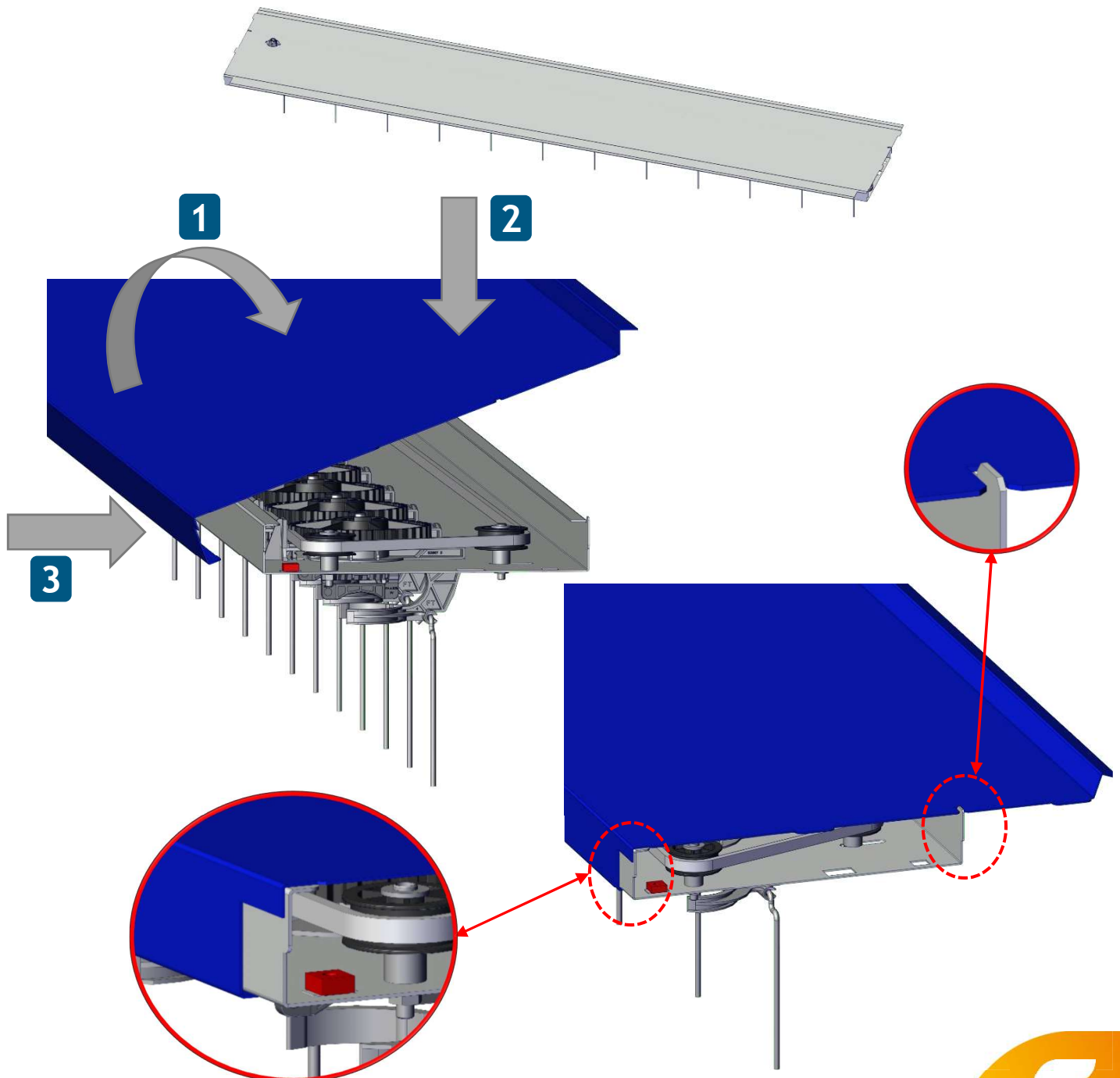



SAFETY PRECAUTIONS :

ALWAYS PROTECT HANDS WITH INDUSTRIAL SAFETY GLOVES WEAR SUITABLE EYEWEAR PROTECTION
DISCONNECT THE MACHINE FROM THE ELECTRICAL SOURCE BEFORE MAINTENANCE
DO NOT SMOKE OR IGNITE AN OPEN FLAME NEAR EXPLOSIVE PAINTS AND CHEMICALS

INSTALLATION

Installing the others Mixing Shelves and the galvanized shelf covers

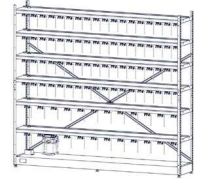

Step 14: To install the mechanical shelves, remove shelf cover, then align them with the front and rear tabs on the shelf brackets.

Note 1: it is important that each shelf is locked into BOTH tabs, or the shelf will be installed incorrectly and could impair the mixing performance.

Note 2: It is important to follow the order of assembly: mixing shelves then covered shelves before moving on the next level.

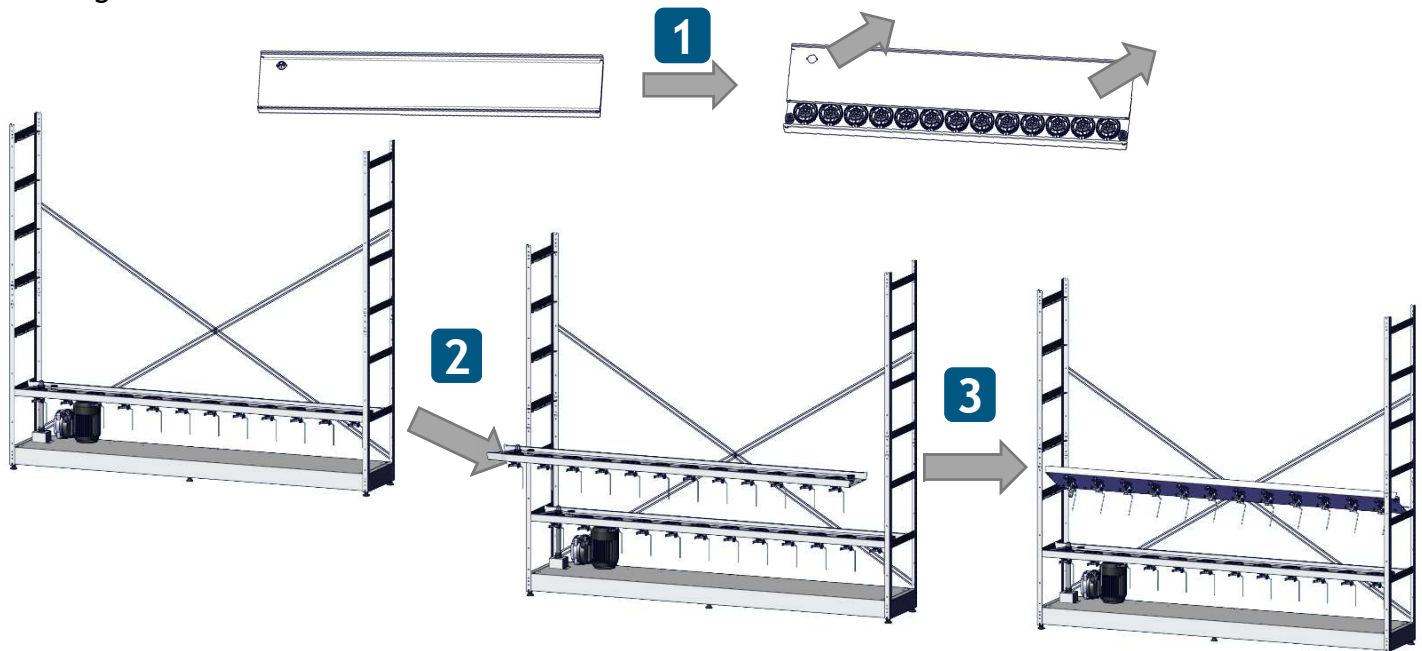

Note: When installing mixing shelves, it is important to PUSH the shelf backward and then PULL forward to lock it securely into place.

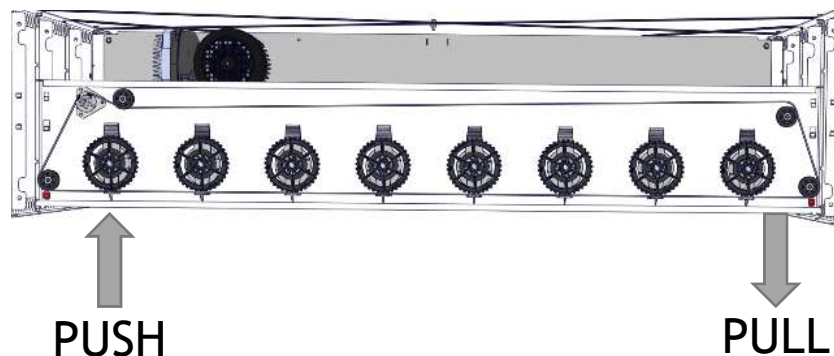



SAFETY PRECAUTIONS :

ALWAYS PROTECT HANDS WITH INDUSTRIAL SAFETY GLOVES WEAR SUITABLE EYEWEAR PROTECTION
DISCONNECT THE MACHINE FROM THE ELECTRICAL SOURCE BEFORE MAINTENANCE
DO NOT SMOKE OR IGNITE AN OPEN FLAME NEAR EXPLOSIVE PAINTS AND CHEMICALS

INSTALLATION

Installing the others Mixing Shelves and the galvanized shelf covers



Step 15: Install the shelf cover on the top of the mechanical shelf.

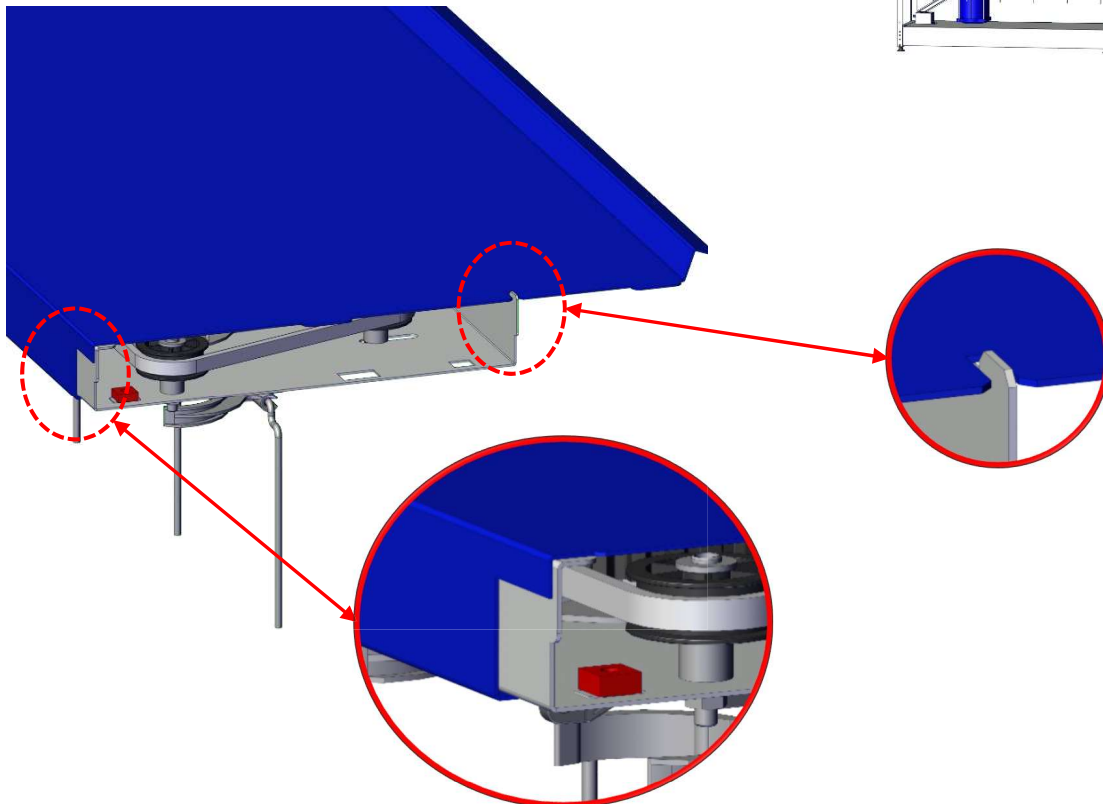
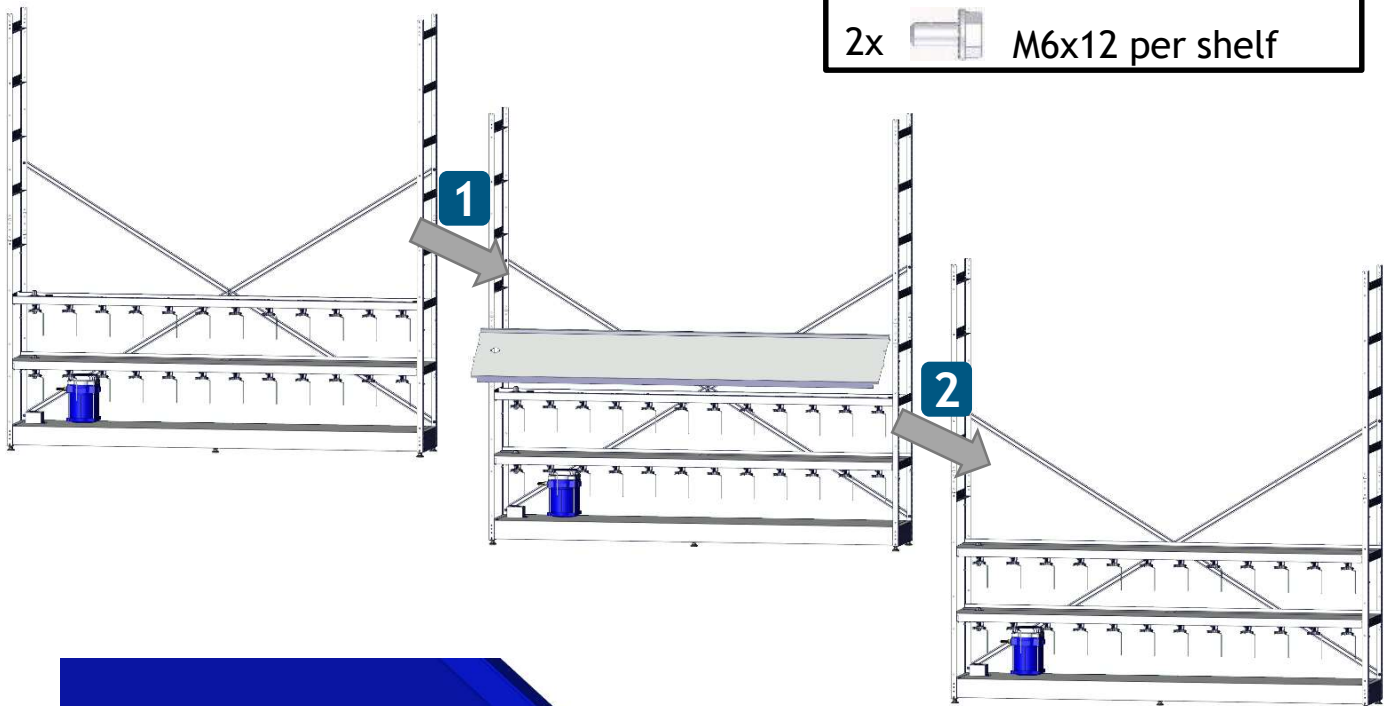





SAFETY PRECAUTIONS :

ALWAYS PROTECT HANDS WITH INDUSTRIAL SAFETY GLOVES WEAR
SUITABLE EYEWEAR PROTECTION
DISCONNECT THE MACHINE FROM THE ELECTRICAL SOURCE BEFORE
MAINTENANCE
DO NOT SMOKE OR IGNITE AN OPEN FLAME NEAR EXPLOSIVE PAINTS AND
CHEMICALS

INSTALLATION

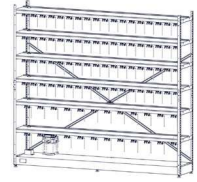
Installing the others Mixing Shelves and the
galvanized shelf covers



2x  M6x12 per shelf





SAFETY PRECAUTIONS :

ALWAYS PROTECT HANDS WITH INDUSTRIAL SAFETY GLOVES WEAR SUITABLE EYEWEAR PROTECTION
DISCONNECT THE MACHINE FROM THE ELECTRICAL SOURCE BEFORE MAINTENANCE
DO NOT SMOKE OR IGNITE AN OPEN FLAME NEAR EXPLOSIVE PAINTS AND CHEMICALS

INSTALLATION

Installing the rear support

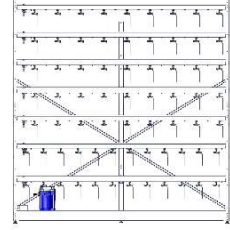

Step 16: Install the rear support.

Mount the rear support without removing the cross-braces. Simply fix it to them using the M6x20 screw and add a nut.

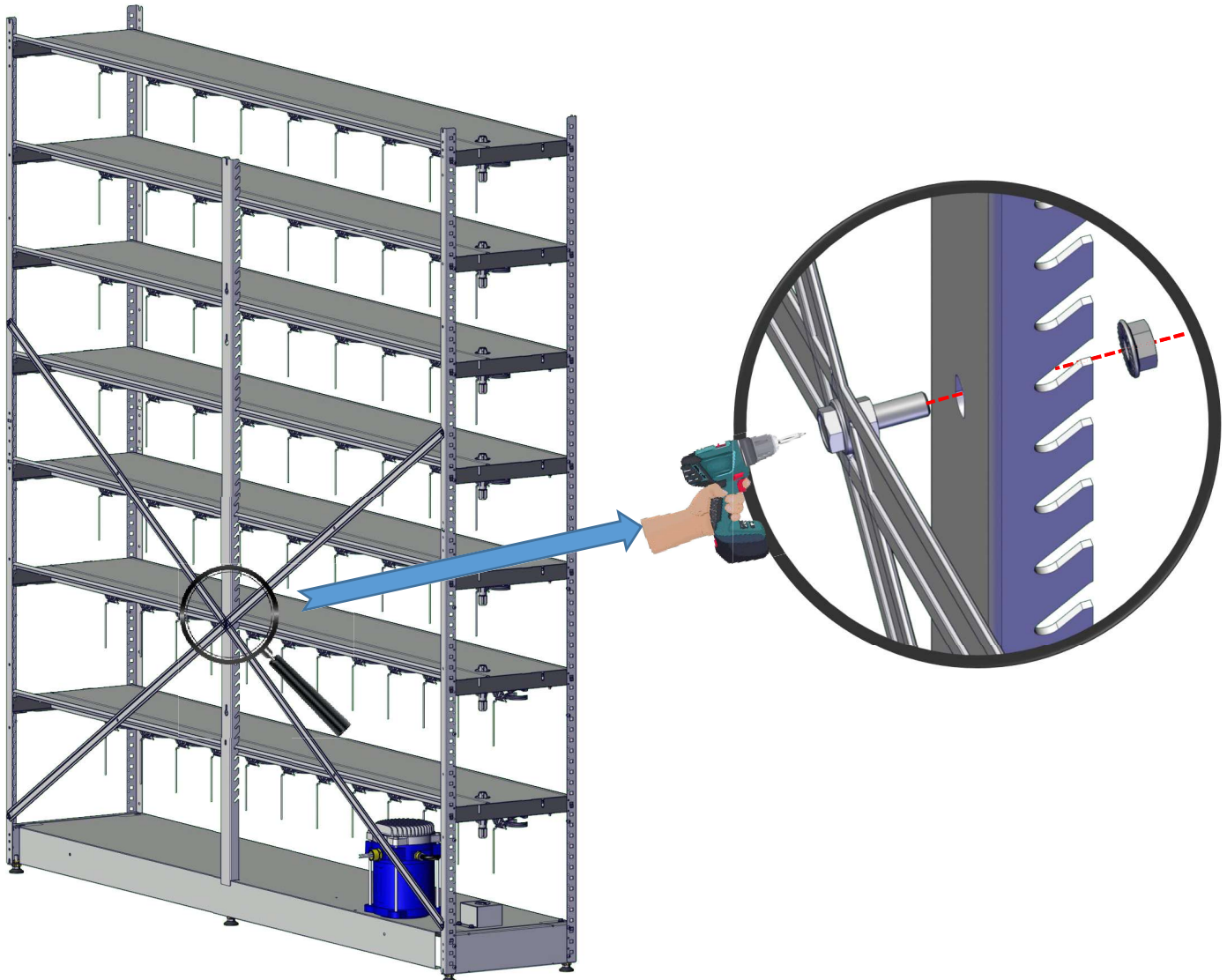



SAFETY PRECAUTIONS :

ALWAYS PROTECT HANDS WITH INDUSTRIAL SAFETY GLOVES WEAR SUITABLE EYEWEAR PROTECTION
DISCONNECT THE MACHINE FROM THE ELECTRICAL SOURCE BEFORE MAINTENANCE
DO NOT SMOKE OR IGNITE AN OPEN FLAME NEAR EXPLOSIVE PAINTS AND CHEMICALS

INSTALLATION

Installing the rear support Only for gallons

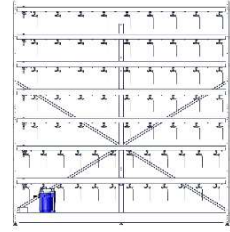

4x  M6x12

Step 17: Slide the rear bracket into the rear rail. Tighten the 4 screws.

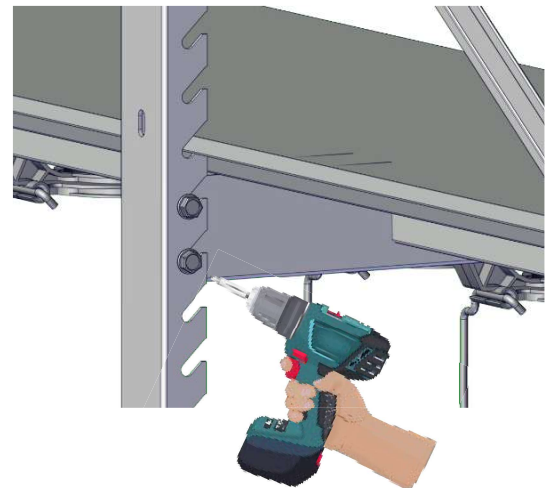
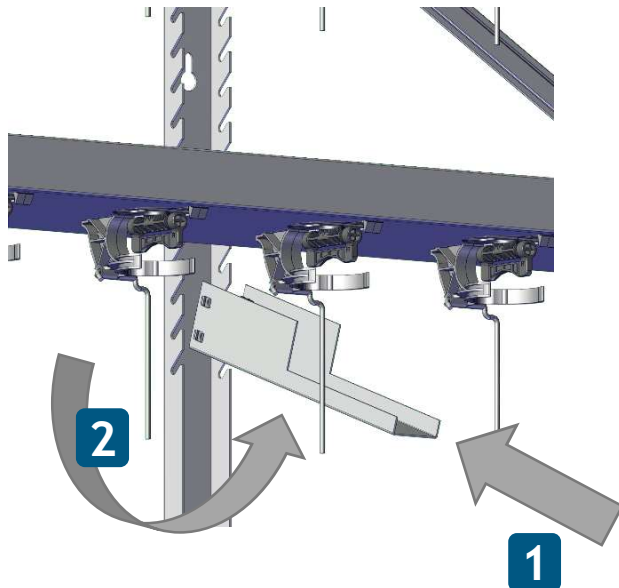
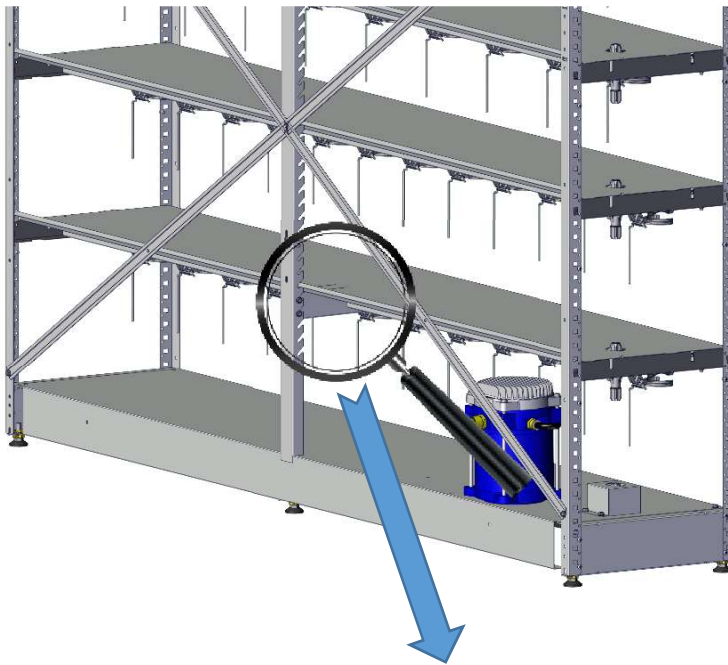



SAFETY PRECAUTIONS :

ALWAYS PROTECT HANDS WITH INDUSTRIAL SAFETY GLOVES WEAR SUITABLE EYEWEAR PROTECTION
DISCONNECT THE MACHINE FROM THE ELECTRICAL SOURCE BEFORE MAINTENANCE
DO NOT SMOKE OR IGNITE AN OPEN FLAME NEAR EXPLOSIVE PAINTS AND CHEMICALS

INSTALLATION

Installing the drive shafts (other mixing shelves...)

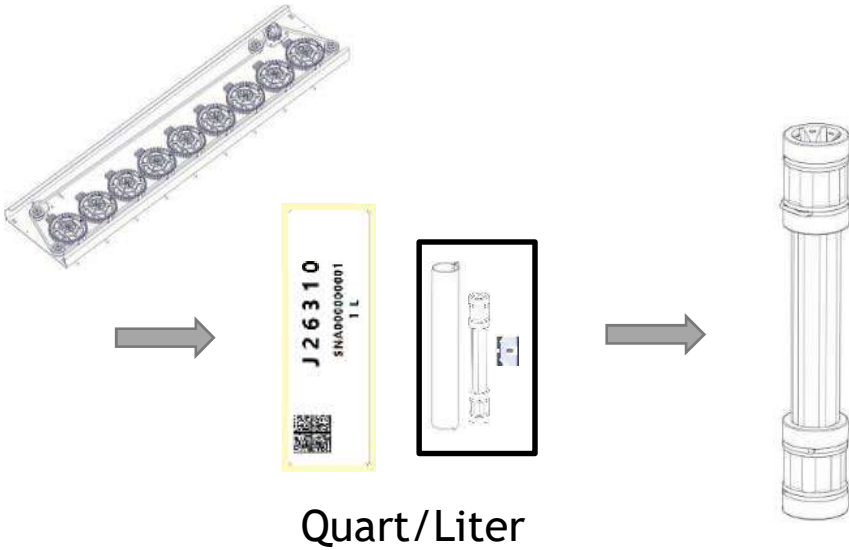
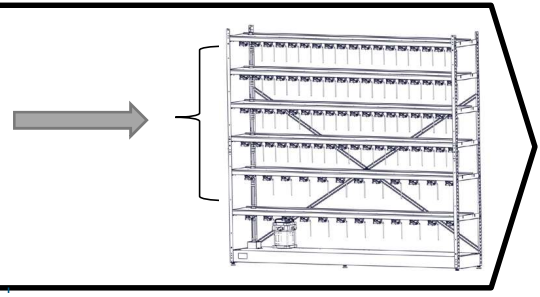

Quart/Liter

Step 18: Install the drive shafts on the transmission side by inserting the shaft into the upper end and then allowing the lower drive sleeve to fall downward and lock into place. To ensure that you have it installed correctly give it a slight twist with your hand.

Note: The drive shafts only have one retainer clip on the top drive sleeve.

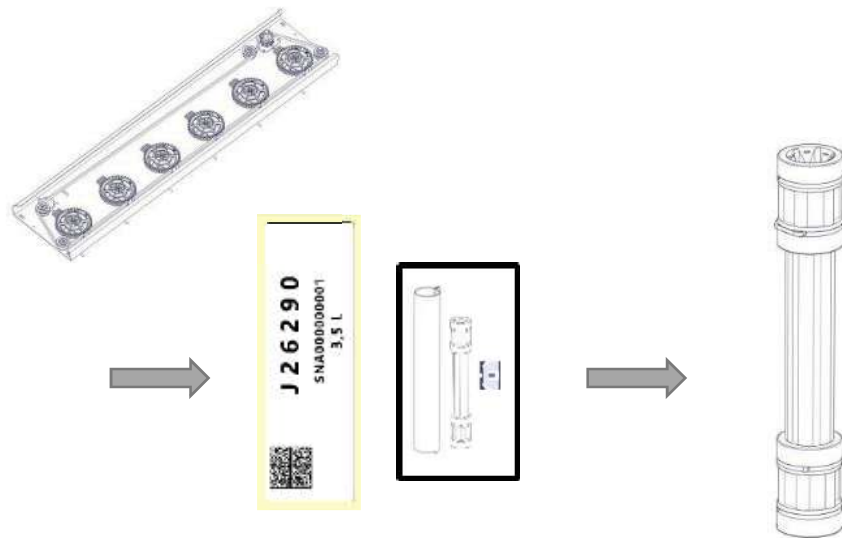

Gallon/3.5-Liter

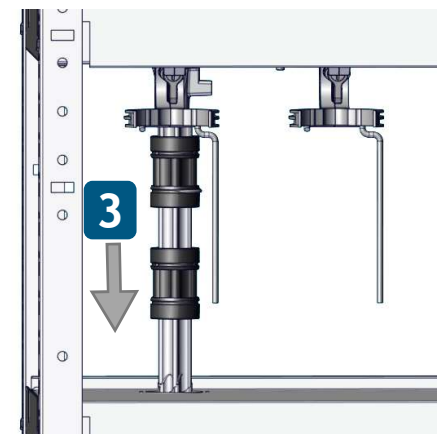
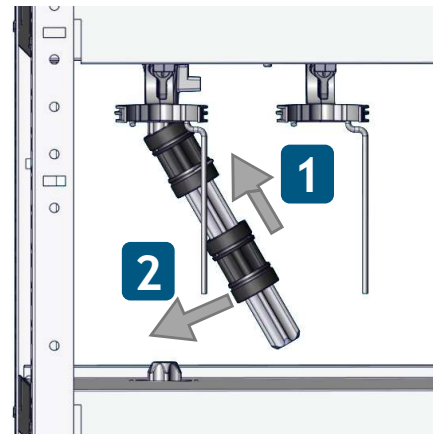



SAFETY PRECAUTIONS :

ALWAYS PROTECT HANDS WITH INDUSTRIAL SAFETY GLOVES WEAR SUITABLE EYEWEAR PROTECTION
DISCONNECT THE MACHINE FROM THE ELECTRICAL SOURCE BEFORE MAINTENANCE
DO NOT SMOKE OR IGNITE AN OPEN FLAME NEAR EXPLOSIVE PAINTS AND CHEMICALS

INSTALLATION

Installing the protective drive shaft covers

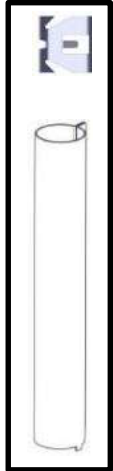
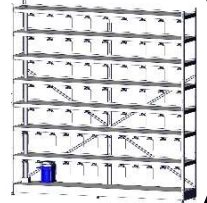

Step 19: Attach the protective covers on each drive shaft assembly and secure in place with the clip.

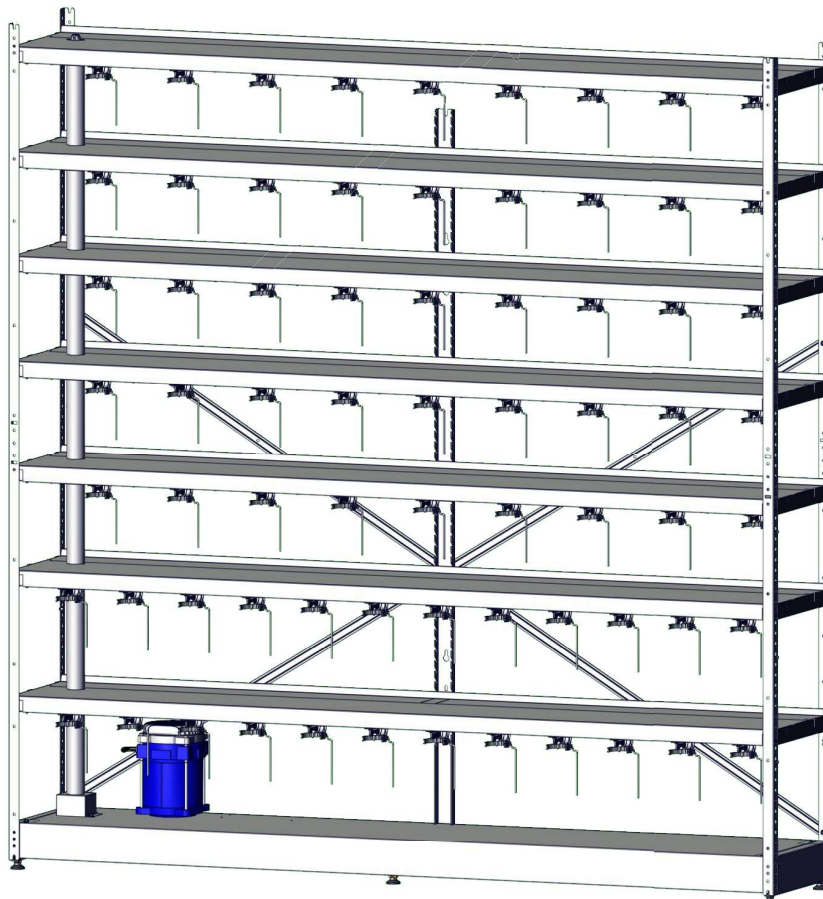
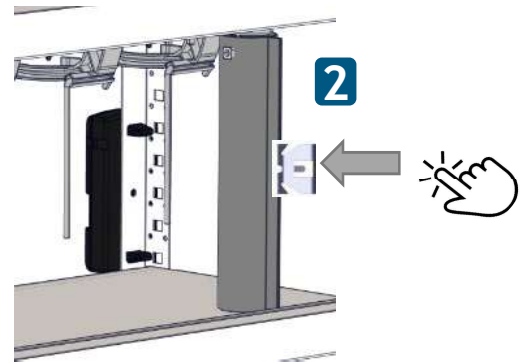
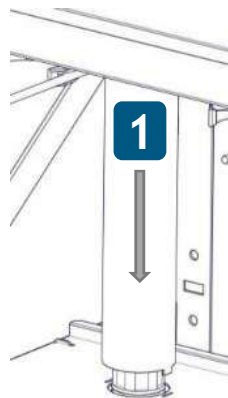



SAFETY PRECAUTIONS :

ALWAYS PROTECT HANDS WITH INDUSTRIAL SAFETY GLOVES WEAR SUITABLE EYEWEAR PROTECTION
DISCONNECT THE MACHINE FROM THE ELECTRICAL SOURCE BEFORE MAINTENANCE
DO NOT SMOKE OR IGNITE AN OPEN FLAME NEAR EXPLOSIVE PAINTS AND CHEMICALS

INSTALLATION

Installing the Header Board

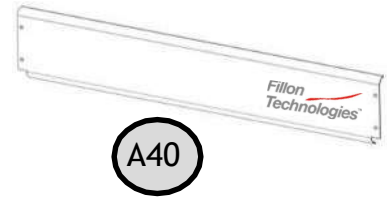
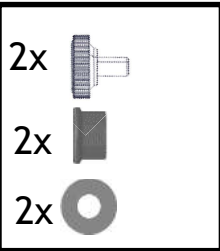
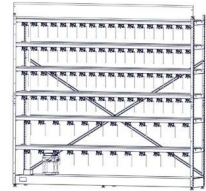

C4 Step 20: While using a step stool, add the RED safety cover by inserting it over the last (top) driveshaft.

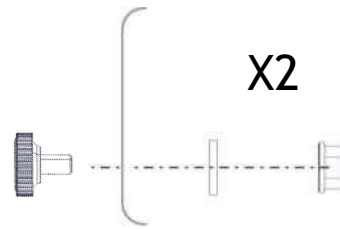
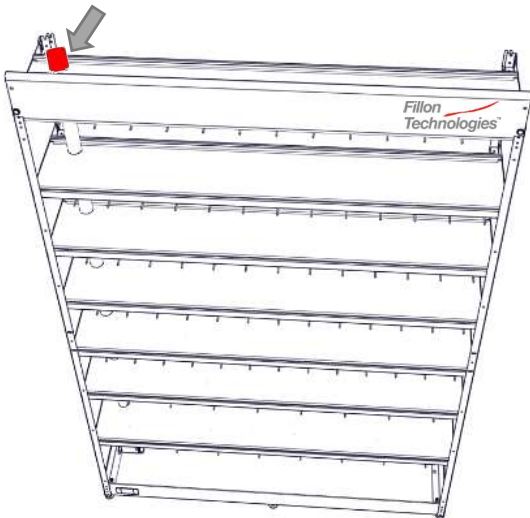

X2

Step 21: Attach the Header Board to the top of the uprights by using the two serrated locking rollers provided on each end.

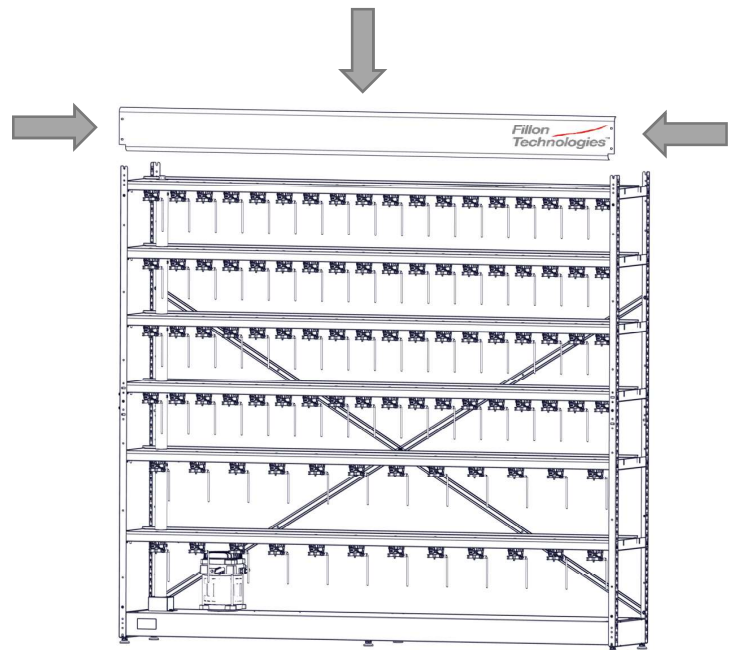

Caution: Do not step on top of a mixing shelf if you cannot reach.





SAFETY PRECAUTIONS :

ALWAYS PROTECT HANDS WITH INDUSTRIAL SAFETY GLOVES WEAR SUITABLE EYEWEAR PROTECTION
DISCONNECT THE MACHINE FROM THE ELECTRICAL SOURCE BEFORE MAINTENANCE
DO NOT SMOKE OR IGNITE AN OPEN FLAME NEAR EXPLOSIVE PAINTS AND CHEMICALS

INSTALLATION

Installing the black pins

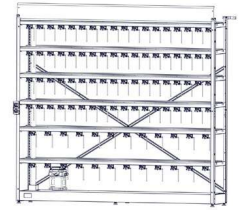

73x

Step 22: Insert the black plastic pins into each holes of the structure (16 front left + 19 front right + 2x19 rear).

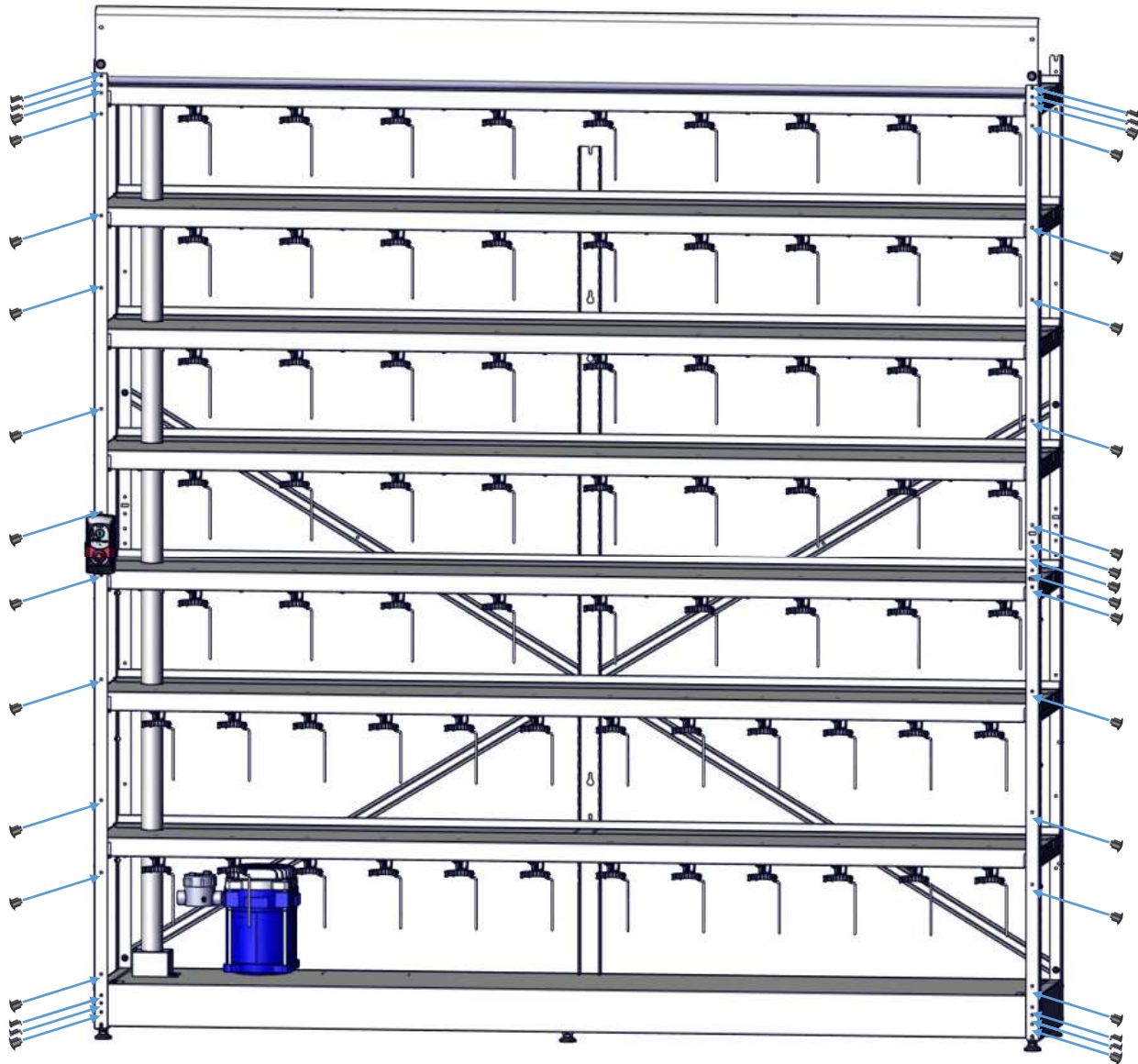





SAFETY PRECAUTIONS :

ALWAYS PROTECT HANDS WITH INDUSTRIAL SAFETY GLOVES WEAR SUITABLE EYEWEAR PROTECTION
DISCONNECT THE MACHINE FROM THE ELECTRICAL SOURCE BEFORE MAINTENANCE
DO NOT SMOKE OR IGNITE AN OPEN FLAME NEAR EXPLOSIVE PAINTS AND CHEMICALS

INSTALLATION

Mounting the Programmable Timer



2x  M6x12 2x 

Dempro



Step 23: Install the programmable timer into the LH front side rail slots as indicated.

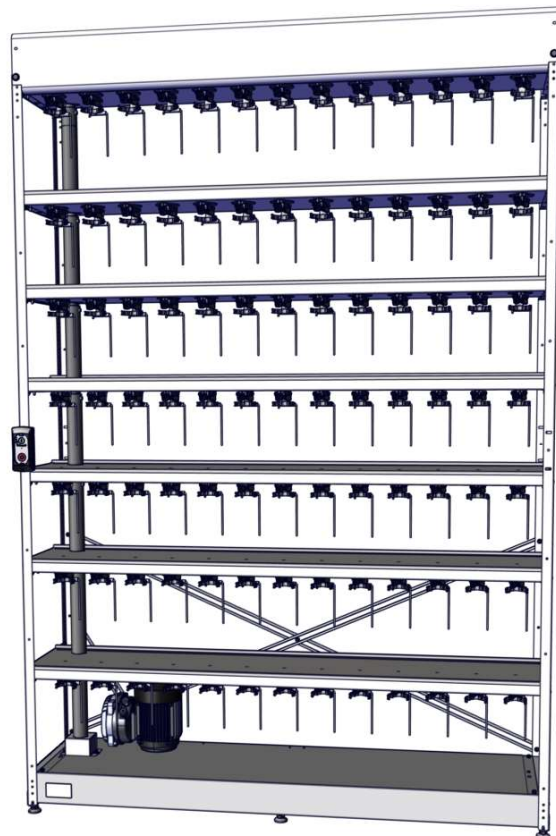
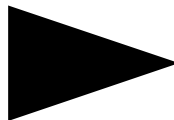
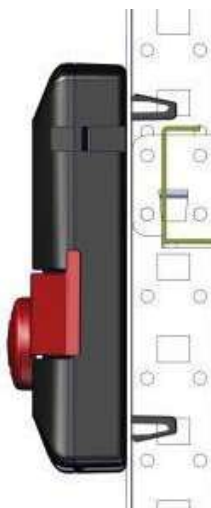



SAFETY PRECAUTIONS :

ALWAYS PROTECT HANDS WITH INDUSTRIAL SAFETY GLOVES WEAR SUITABLE EYEWEAR PROTECTION
DISCONNECT THE MACHINE FROM THE ELECTRICAL SOURCE BEFORE MAINTENANCE
DO NOT SMOKE OR IGNITE AN OPEN FLAME NEAR EXPLOSIVE PAINTS AND CHEMICALS

INSTALLATION

Wall-Mount Brackets

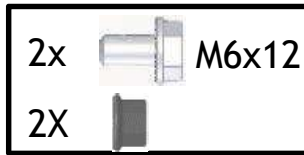
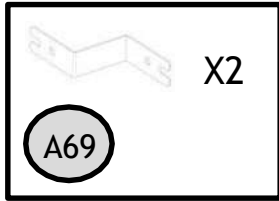
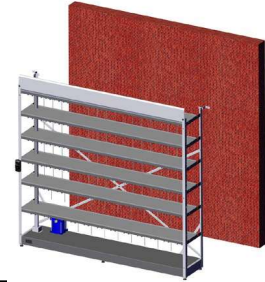

Step 24: Secure the machine against the wall by using the brackets provided.

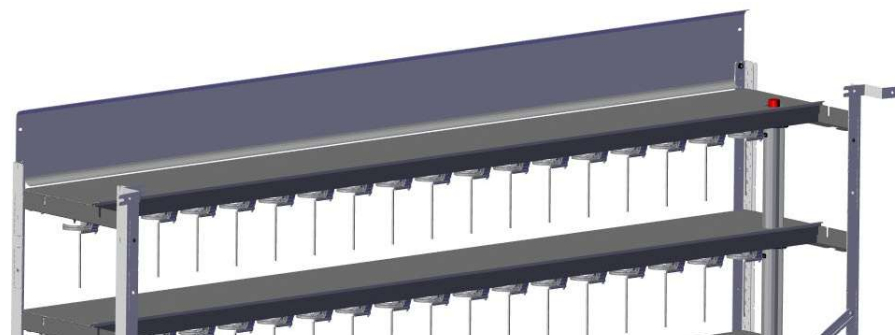
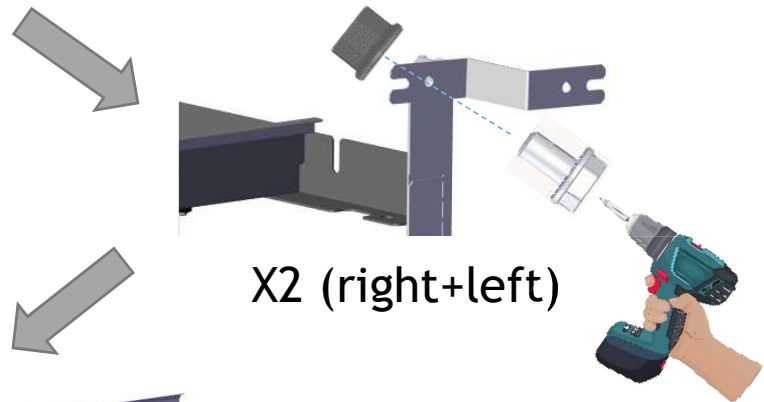
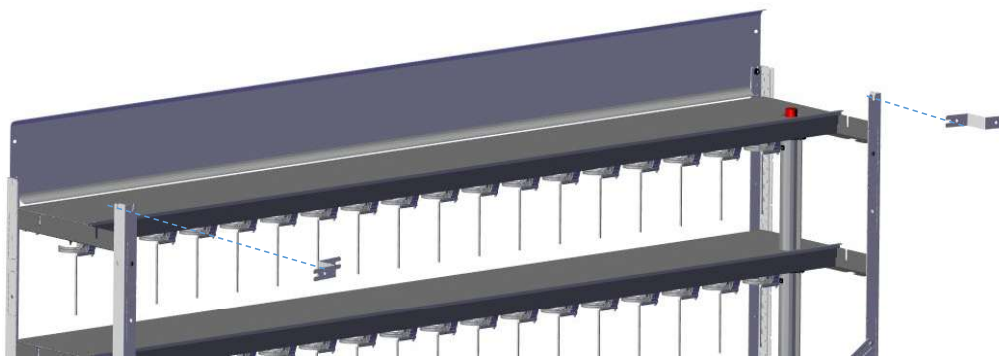



SAFETY PRECAUTIONS :

ALWAYS PROTECT HANDS WITH INDUSTRIAL SAFETY GLOVES WEAR SUITABLE EYEWEAR PROTECTION
DISCONNECT THE MACHINE FROM THE ELECTRICAL SOURCE BEFORE MAINTENANCE
DO NOT SMOKE OR IGNITE AN OPEN FLAME NEAR EXPLOSIVE PAINTS AND CHEMICALS

CONFIGURATIONS GUIDE

☐ Below are some general guidelines to follow if ordering an Alpha-Mix 160/220 Structure and base assembly for a custom configuration.

POSSIBLE CONFIGURATIONS

Alpha-Mix 160 or 220	Alpha-Mix 160 (by toner count)	Alpha-Mix 220 (by toner count)
1 Gal. + 6 Qt. Shelves	8 gallons + 78 quarts	12 gallons + 108 quarts
2 Gal. + 5 Qt. Shelves	16 gallons + 65 quarts	24 gallons + 90 quarts
3 Gal. + 4 Qt. Shelves	24 gallons + 52 quarts	36 gallons + 72 quarts
4 Gal. + 2 Qt. Shelves	32 gallons + 26 quarts	48 gallons + 36 quarts
5 Gal. + 1 Qt. Shelves	40 gallons + 13 quarts	60 gallons + 18 quarts
6 Gal. Shelves	48 gallons	72 gallons
7 Qt. Shelves	91 quarts	126 quarts





SAFETY PRECAUTIONS :

ALWAYS PROTECT HANDS WITH INDUSTRIAL SAFETY GLOVES WEAR SUITABLE EYEWEAR PROTECTION
DISCONNECT THE MACHINE FROM THE ELECTRICAL SOURCE BEFORE MAINTENANCE
DO NOT SMOKE OR IGNITE AN OPEN FLAME NEAR EXPLOSIVE PAINTS AND CHEMICALS

ELECTRICAL INSTALLATION

Installations must be carried out by a qualified (licensed) electrician in accordance with all local safety and fire regulations for hazardous location usage.

Paint mixing equipment must be installed in well-ventilated rooms specifically designated and zoned for hazardous location (Class 1, Division 1, Group D).

Paint mixing equipment must be installed in areas specifically zoned for hazardous locations (Class 1, Division 1, and Group D).

Site installation is subject to acceptance to the local inspection authority having jurisdiction.

The motor plate includes the CSA stamp of Approval for usage in hazard locations.

IMPORTANT GUIDELINES:

The motor should never be fitted with a plug and connected into a wall outlet. Hazardous regulations require that it must be hardwired in accordance with the local safety requirements. There is also a risk that a power surge could damage the internal electronics.

The installation requires a minimum of a 15 Amp Circuit breaker.

The motor features a pre-installed explosion-proof Junction box to facilitate the installation. To access the wires, simply unscrew the cap.

Never attempt to modify or repair an explosion-proof motor.

For technical assistance, please contact Fillon Technologies at: 800-777-1583. The motor/timer includes a 2-year warranty from the shipping date.

Fillon assumes no responsibility or liability for actions taken beyond the scope of this warning.

CAUTION

Alpha-Mix machines are equipped with a single-phase, explosion-proof 550 Watt Motor (120V/60 Hz) and an intrinsically safe timer that complies with UL and CSA Standards (Class 1, Division 1, Group D) for usage in hazardous locations.

The motor is equipped with internal overheat protection and will automatically shut-off. The motor is not intended to be running continuously.

SWIVEL (180° C) CONDUIT
ELBOW ½ - 14 N.P.T.

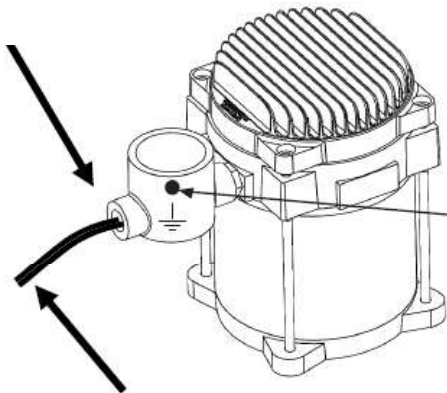

The motor and mixing machine must be grounded using the cords and screws provided. Refer to NEC article 250 (Grounding) for additional information.
All wiring must be done by a qualified electrician.

TWO LINE LEADS TO EXTEND 62'' + 2-0 FROM: OF CONDUIT BOSS WITH 44'' STRIPPING. LEAD MATERIAL NO. 16 AWG WITH CROSS-LINK POLYETHYLENE INSULATION. 600V. 125°C GASOLINE AND OIL RESISTANT. UL & CSA APPROVED.





SAFETY PRECAUTIONS :

ALWAYS PROTECT HANDS WITH INDUSTRIAL SAFETY GLOVES WEAR SUITABLE EYEWEAR PROTECTION
DISCONNECT THE MACHINE FROM THE ELECTRICAL SOURCE BEFORE MAINTENANCE
DO NOT SMOKE OR IGNITE AN OPEN FLAME NEAR EXPLOSIVE PAINTS AND CHEMICALS

OPERATION

Pull the gates into the downward position as shown to prevent cans from spinning and falling off the mixing machine during operation.

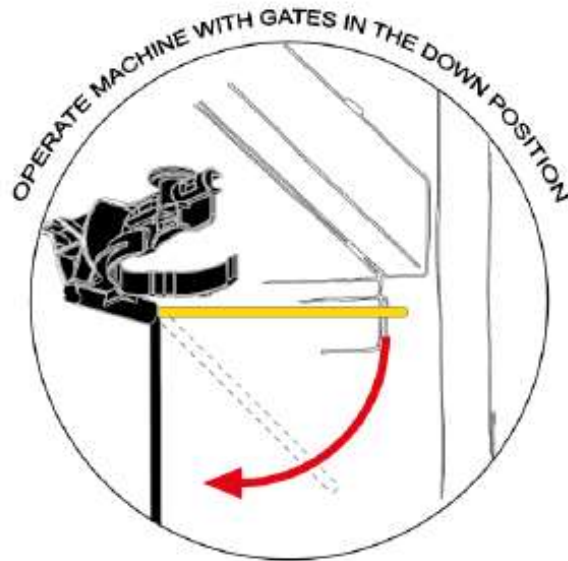

- ▶ Use only mixing lids equipped with Quick-Link ("QL") drive forks.
- ▶ The timer is pre-set to run for 15-minutes maximum (twice daily) in accordance with the guidelines for stirring primers as mandated by the paint manufacturers.
- ▶ Containers can be removed and replaced safely while the mixing machine is running.
- ▶ Each mixing machine position is equipped with an over-torque clutch to prevent can rejection. If a can is dented the operator will hear a distinct "clicking" sound to alert him to transfer the contents into a new can.
- ▶ After the machine starts, containers will turn slightly until the pouring spouts lock into position against the gates. This is normal and provides sure-fire mixing.

ALWAYS MAKE SURE THE OPERATORS ARE TRAINED AND FAMILIAR WITH THE MIXING MACHINE BEFORE USING.





SAFETY PRECAUTIONS :

ALWAYS PROTECT HANDS WITH INDUSTRIAL SAFETY GLOVES WEAR SUITABLE EYEWEAR PROTECTION
DISCONNECT THE MACHINE FROM THE ELECTRICAL SOURCE BEFORE MAINTENANCE
DO NOT SMOKE OR IGNITE AN OPEN FLAME NEAR EXPLOSIVE PAINTS AND CHEMICALS

PROGRAMMING THE TIMER

MANUAL MODE:

When power is delivered to the timer the LED indicator button will blink GREEN rapidly. To initiate mixing, press the green START button and hold it for 2-seconds...The LED will blink in ORANGE and then GREEN. The motor will begin by turning slowly and take 20-seconds to reach full speed.

If you want to STOP the mixing cycle before the program has finished press the RED stop bar.

AUTOMATED MIXING:

Press and hold the RED stop bar until the LED indicator turns ORANGE then release. Next, press the green START button and hold it for 1-2 seconds. The indicator light will blink ORANGE for 10-seconds and then the mixing cycle will commence.

The SECOND mixing cycle will begin exactly 5-hours and 45-minutes AFTER the first cycle is completed.

Important: if after completing the above steps and the LED indicator is a solid GREEN, repeat the programming steps to initialize.

STARTING TIMES FOR AUTOMATED MIXING:

If you want the automated mixing program to begin at a specific time each day, a person will need to be present at that exact time to program the motor as explained above.

POWER OUTAGE

If the painter arrives at the shop and notices the LED indicator blinking GREEN repeatedly, it means that there was a power outage. The paint should be stirred immediately in manual mode. The painter will also need to re-program the timer according to his preferred starting time for the automated mixing mode since the memory was lost during the outage.

TROUBLESHOOTING

If the timer led blinks RED several times and won't start in the manual mode then the motor needs to be replaced. Call Fillon Technologies to arrange a replacement. Note: the warranty is valid 2-years from the shipping date.

To determine if your equipment is still covered under warranty the serial number is required. The S/N for the Dempro motor is located on the side of the timer as shown in the photo on the right.

Example: SN1000373209 or A000112616

For more information and view the Dempro motor Tutorial video visit the Fillon Technologies Workshop on YouTube.





SAFETY PRECAUTIONS :

ALWAYS PROTECT HANDS WITH INDUSTRIAL SAFETY GLOVES WEAR SUITABLE EYEWEAR PROTECTION
DISCONNECT THE MACHINE FROM THE ELECTRICAL SOURCE BEFORE MAINTENANCE
DO NOT SMOKE OR IGNITE AN OPEN FLAME NEAR EXPLOSIVE PAINTS AND CHEMICALS

TROUBLESHOOTING

GENERAL RECOMMENDATIONS

- ❑ ALWAYS DISCONNECT THE POWER FROM THE CIRCUIT BOARD BEFORE ATTEMPTING REPAIRS.
- ❑ FILLON TECHNOLOGIES ASSUMES NO RESPONSIBILITY FOR DAMAGES OR INJURIES RESULTING FROM FAILURE TO OBSERVE THE SAFETY PRECAUTIONS.
- ❑ Periodically perform a routine service check on the mixing machine. Check to ensure the tension of the belts and other wearable components. Spare parts can be ordered directly from Fillon Technologies at 800-777-1583 or www.fillontechus.com.
- ❑ Whenever possible wipe paint runs from the mix shelves and agitator lids with a mild cleaning product. Dust particles can be removed with a damp cloth. NEVER wash down the mixing machine with running water.

QUICK-REFERENCE TROUBLE-SHOOTING

PROBLEM	SOLUTIONS
The control box LED light is not on	Check that electricity is being delivered to the motor (110V/60Hz)
The motor is not running	If the motor is not working, the LED will likely blink RED repeatedly. In such cases, contact Fillon Technologies at: 800-777-1583 to arrange having them send a replacement motor.
The stirrers are not turning the mixing lids	DISCONNECT THE POWER TO THE MACHINE. Next, disengage and remove the middle drive shaft to see if the bottom cans spin. If they are, then reinstall the driveshaft and remove the driveshaft from the top shelf. Doing this will determine which shelf has the issue. Once the shelf with an issue is identified, open the shelf to inspect the belt, rollers and driveshaft. Call Fillon to order the needed spare parts.
The machine is running noisy (above 78db)	Check the condition of the belts and the tightness of each including the motor belt. Also, inspect the condition of all parts on the transmission.





SAFETY PRECAUTIONS :

ALWAYS PROTECT HANDS WITH INDUSTRIAL SAFETY GLOVES WEAR SUITABLE EYEWEAR PROTECTION
 DISCONNECT THE MACHINE FROM THE ELECTRICAL SOURCE BEFORE MAINTENANCE
 DO NOT SMOKE OR IGNITE AN OPEN FLAME NEAR EXPLOSIVE PAINTS AND CHEMICALS

SPARE PARTS

To order a spare part, please provide the information on the manufacturer's identification plate, located on the base shelf of the machine.



SPARE PARTS	Id	REFERENCE
Drive sleeve & retainer clip	C5	AYYY1448
Drive shaft protection clip	C22	AYYY1475
Dempro motor assembly	D1	AREL1001
Motor belt	A27	AYYY1019
Shelf belt	B21	Alpha-Mix 160 = AYYY1415 Alpha-Mix 220 = AYYY1416
Shelf Belt Roller	B22	AYYY1134
Main Drive block with pulley	A9	AYYY1412
Shelf drive block	C10	AYYY1446
Quick-Link assembly	C9	AYYY1137
0,5L Drive shaft assembly with protective cover	C3	AYYY1440
Quart drive shaft with protective cover	C3	AYYY1441/AYYY1447* * For base shelf position
Gallon drive shaft with protective cover	C3	AYYY1442/AYYY1443* * For base shelf position

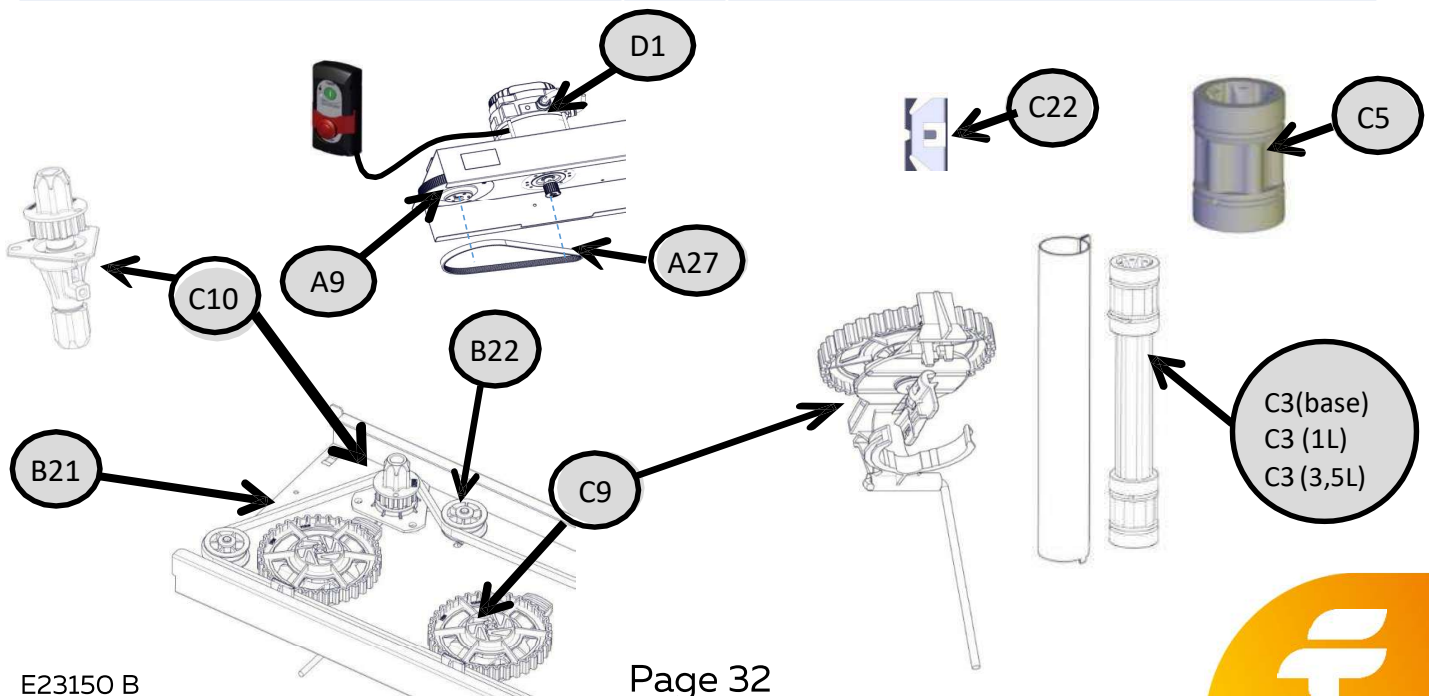

WARRANTY MOTOR POLICY

Alpha-Mix machines and Dempro Motors are warranted for 2-years after the date it leaves our warehouse facilities.

CLAIMS PROCEDURE

To determine if your equipment is covered, serial numbers are required. The S/N for the Dempro 'slow-start' motor is located on the side of the programmable timer and the S/N from the base shelf as shown in the photo below.

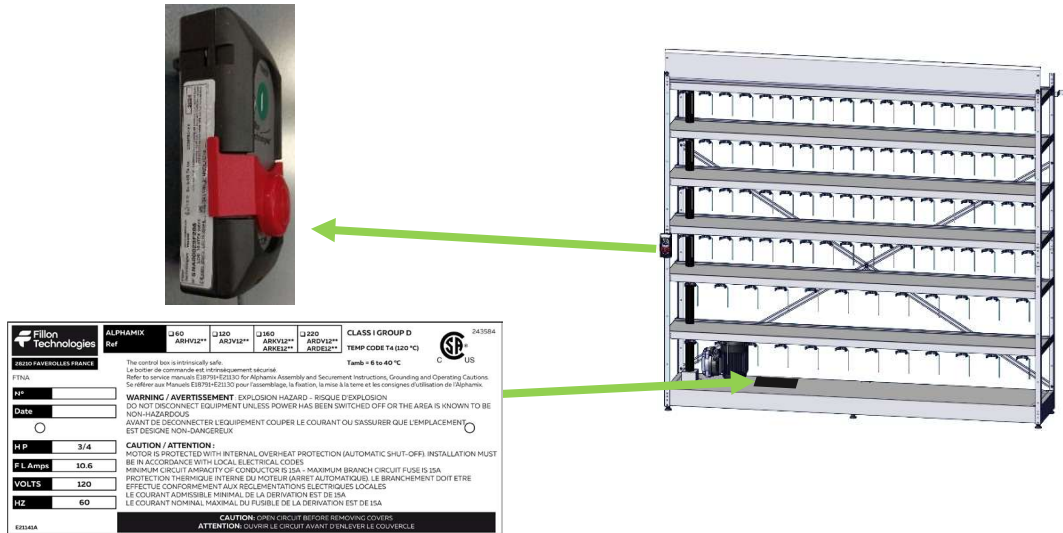

If your motor is still covered under warranty, a replacement motor/timer will be sent at no charge. You will be instructed to re-use the existing motor mounting plate. Replacement motor will be shipped using standard ground shipping unless approved by management. Re-installation instructions will be provided upon request.

Please note: Fillon is not responsible for any electrician expenses incurred as a result of a motor failure.

For any machine components needed, please indicate the part # from page 28 of this manual.

For more detailed technical information about the Dempro motor watch the online tutorial



For questions or concerns call: 1-800-777-1583
or email: customerserviceUS@fillontech.com





Game changer of your market !!

